



TONIN CASA s.r.l.
Via Palladio, 43
S.Giorgio in Bosco
35010 PADOVA
Tel. +39 049 945 3300
Fax + 39 049 945 0725
info@tonincasa.it
www.tonincasa.it

Home *design living*



My Home

design living

MADE IN ITALY



My Home

design living

MY HOME....Design Living

Passione per la casa. Design e fascino alleati in un progetto fatto di materia e di colore, tra i toni scuri e chiari, con pezzi cult che arredano senza tempo. Sentimenti, ricordi, simboli... la casa è un "micro mondo" che contiene una vita e Tonin Casa si impegna ad arricchire questo mondo con il suo stile 100% Italiano. Varietà di forme, dimensioni e colori, materiali caldi e preziosi come il legno ed il marmo concepiti come piccole sculture.

MY HOME....Design Living

Passion for the home. Design and appeal, together in a project made of substance and colour, through dark and light tones, with cult pieces that create timeless furnishing. Feelings, memories, symbols...home is a micro world that contains life and Tonin Casa is committed to enrich this world with its style, 100% Italian. Variety in form, dimension and colour, warm and precious materials such as wood and marble conceived as small sculptures.

A tutto vogliamo dare un senso in particolare alla casa poiché vi trascorriamo gran parte della nostra vita, perché è la nostra dimora sicura e come tale merita solo il meglio... un prodotto totalmente progettato, realizzato e costruito in Italia.

Qualunque sia la ricetta d'arredo, l'importante è l'originalità e l'unicità dei prodotti scelti e noi di Tonin Casa cerchiamo di garantire questo brevettando tutto ciò che facciamo. Un prodotto Tonin Casa è un prodotto per la vita.

We want to give sense to everything, and specifically to "home", as we spend most of our lives here, because it's our safe haven therefore it deserves only the best..a product designed and manufactured in Italy.

Whatever be the furnishing recipe, what matters is the originality and uniqueness of chosen items and us at Tonin Casa makes the most to guarantee this by patenting all our products. A Tonin Casa product is meant for life.



Tonin CASA

Fondata da Gianni Tonin più di 30 anni fa, TONIN CASA è stata sin dall'inizio esempio di passione, eleganza e ricerca nel settore arredamento.

Nel 1975 la sua attività principale era il commercio di scarpieri e mobili classici, pubblicando il primo catalogo nel 1982. Il successo e la fiducia dei clienti fecero sì che nei primi anni '90 venisse avviata la produzione di mobili moderni, accompagnati dall'edizione di cataloghi dedicati ed all'espansione dell'area commerciale oltre il Triveneto.

Tonin casa, da allora, è in costante sviluppo e crescita, impegnata nel commercio a livello mondiale e nell'esportazione dei valori del Made in Italy, con prodotti sintesi di bellezza e funzionalità. Segni e tendenze che promuovono la tradizione del Design Italiano nel mondo.

Founded by Gianni Tonin more than 30 years ago, TONIN CASA has been, since the very beginning, a perfect example of passion, elegance and research in the furniture business.

In 1975 its main activity was the production of shoe cabinets and classical furniture, publishing the first catalogue in 1982.

Due to its success and the trust from our clientele, at the beginning of the Nineties, we started our production of modern furniture, together with publishing of specific dedicated catalogues and the expansion to areas beyond Northern Italy.

Since then, TONIN CASA has been in a continuous development and growth, engaging into worldwide sales and exporting the values of Made in Italy, with products which resume beauty and functionality. Signs and trends that promote the tradition of Italian Design in the world.



INDICE
Index

TAVOLI e CONSOLLE

Tables and Consoles

Alba	58
Altamura	126
Amelia	128
Arcos	64
Arpa	122
Bexley	116
Brooklyn	44
Butterfly	36
Cannaregio	78
Cub	96
Eliseo	100
Gaya e Big Gaya	106
Imperial	110
Manhattan	70
Pure	98
Roma	52
Temple	90
Tokyo	24
Vendôme	84
Wave	12

SEDIE, SGABELLI e POUFF

Chairs, Bar Stools and Poufs

Aragona	140
Aria Easy	182
Asola	192
Belem	162
Carilla	176
Charm	144
Charonne	152
Colette	158
Dalila	164
Deira	172
Ginza	174
Giudecca	160
Madeleine	168
Milano	188
Mivida	134
New York	190
Oslo	184
Plaza	178
Real	186
Sorbona	156
Stella	166
Truly	194
Vittoria	180
Vivienne	148

**CONTENITORI:
PROGRAMMI e MADIE**

*Storage Units:
Systems and Sideboards*

Asia	236
Goya	240
Granada	222
Honey	198
Miami	230
Paris	204
Venice	214

**CONTENITORI:
LIBRERIE e VETRINE**

*Storage Units:
Bookcases and Showcases*

Abaco	246
Aurora	260
Gracia	266
Naviglio	250
Olivella	268
Oregina	264
Osuna	254
Parella	270
Trafalgar	258

PORTA TV

Tv Stands

Cortes	274
Odeon	276

**COMPLEMENTI:
TAVOLINI**

*Occasional Furniture:
Coffee Tables*

Adachi	344
Airone	342
Alaric	326
Alissa	328
Amanda	316
Amaranto	318
Amburgo	312
Amira	284
Andorra	336
Anemone	320
Ariel	332
Arona	296
Central	302
Detroit	340
Diva	346
Dubai	280
Fly	350
Missouri	300
Navile	330
Osowa	298
Parioli	306
Pavones	334
Space	288
Tree	292
Tudor	310

**COMPLEMENTI:
SPECCHIERE**

*Occasional Furniture:
Mirrors*

Costantia	358
Granada	356
Olmi	360
Kolonaky	364
Skin	354
Toshima	362

TAVOLI e CONSOLLE | *Tables and Consoles*



Wave pag. 12



Tokyo pag. 24



Butterfly pag. 36



Brooklyn pag. 44



Roma pag. 52



Alba pag. 58



Arcos pag. 64



Manhattan pag. 70



Cannaregio pag. 78



Vendôme pag. 84



Temple pag. 90



Cub pag. 96



Pure pag. 98



Eliseo pag. 100



Gaya e Big Gaya pag. 106



Imperial pag. 110



Bexley pag. 116



Arpa pag. 122



Altamura pag. 126



Amelia pag. 128

SEDIE, SGABELLI e POUFF | *Chairs, Bar Stools and Poufs*



Mivida pag. 134



Aragona pag. 140



Charm pag. 144



Vivienne pag. 148



Charonne pag. 152



Sorbona pag. 156



Colette pag. 158



Giudecca pag. 160



Belem pag. 162



Dalila pag. 164



Stella pag. 166



Madeleine pag. 168



Deira pag. 172



Ginza pag. 174



Carilla pag. 176



Plaza pag. 178



Vittoria pag. 180



Aria Easy pag. 182



Oslo pag. 184



Real pag. 186



Milano pag. 188



New York pag. 190



Asola pag. 192



Truly pag. 194

CONTENITORI: PROGRAMMI e MADIE | *Storage Units: Systems and Sideboards*



Honey pag. 198



Paris pag. 204



Venice pag. 214



Granada pag. 222



Miami pag. 230



Asia pag. 236



Goya pag. 240

CONTENITORI: LIBRERIE e VETRINE | *Storage units: Bookcases and Showcases*



Abaco pag. 246



Naviglio pag. 250



Osuna pag. 254



Trafalgar pag. 258



Aurora pag. 260



Oregina pag. 264



Gracia pag. 266



Olivella pag. 268



Parella pag. 270

PORTA TV | *Tv Stands*



Cortes pag. 274



Odeon pag. 276

COMPLEMENTI: TAVOLINI | *Occasional Furniture: Coffee Tables*



Dubai pag. 280



Amira pag. 284

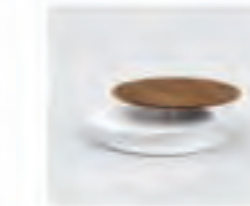

Space pag. 288



Tree pag. 292



Arona pag. 296



Osowa pag. 298



Missouri pag. 300



Central pag. 302



Parioli pag. 306



Tudor pag. 310



Amburgo pag. 312



Amanda pag. 316



Amaranto pag. 318



Anemone pag. 320



Alaric pag. 326



Alissa pag. 328



Navile pag. 330



Ariel pag. 332



Pavones pag. 334



Andorra pag. 336



Detroit pag. 340



Airone pag. 342



Adachi pag. 344



Diva pag. 346



Fly pag. 350

COMPLEMENTI: SPECCHIERE | *Occasional Furniture: Mirrors*



Skin pag. 354



Granada pag. 356



Costantia pag. 358



Olmi pag. 360



Toshima pag. 362



Kolonaky pag. 364

Tavoli e consolle
*tables
and consoles*

*Wave
Tokyo
Butterfly
Brooklyn
Roma
Alba
Arcos
Manhattan
Cannaregio
Vendôme
Temple
Cub
Pure
Eliseo
Gaya
Big Gaya
Imperial
Bexley
Arpa
Altamura
Amelia*



WAVE

design by Studio 28

TAVOLO WAVE ART. T8014 P/A/G/D/FP/FA/FG/FD/ER

*Tavolo fisso o allungabile con binario in alluminio, piano in vetro temperato, legno o marmo.
Basamento stampato in Baydur®, materiale che riunisce libertà creativa e funzionalità.
Wave arreda la tua casa all'insegna del design più estremo dando la possibilità di personalizzare
il colore della base scegliendo il RAL preferito.*

*Fixed or extendible table with aluminium track guide mechanism, top in tempered glass, wood or marble .
Base in moulded Baydur®, a material that couples creative liberty and functionality.
Wave furnishes your home using the most extreme design, adding the possibility
of customizing the base by choosing your favourite RAL colour.*



Wave - Art.8014B 502 V84A
Tavolo allungabile con binario in alluminio brillantato, base stampata in Baydur laccata nero lucido e piano in vetro temperato bronzato trasparente.
Extendible table with polished aluminium mechanism, base in black glossy lacquered Baydur and top in tempered bronzed transparent glass.

WAVE

design by Studio 28

Wave_Art. 8014B 502 V84A

Tavolo allungabile con binario in alluminio brillantato, base stampata in Baydur laccata nero lucido e piano in vetro temperato bronzato trasparente.

Extendible table with polished aluminium mechanism, base in black Glossy lacquered Baydur and top in tempered bronzed transparent glass.

Sorbona_Art. 7295 P60

Sedia interamente rivestita in pelle marrone chiaro

Chair entirely covered in light brown leather.

Granada_Art. 8613 14 V84B LS

Vetrina in noce canaletto con ante in vetro trasparente bronzato e serigrafato. Maniglie Swarovski® e luce led interna.

Showcase in canaletto walnut with doors in transparent bronzed glass with serigraphy. Knobs in Swarovski® and internal LED lighting.

WAVE

design by Studio 28

Wave rappresenta il massimo della personalizzazione; colori base RAL, piani in legno, vetro, fissi o allungabili ti permettono di adattare questo tavolo ad ogni ambiente e ad ogni esigenza.

Wave represents the maximum in personalization; base in RAL colours, top in wood, glass, fixed or extendible allow to adapt this table to any ambience and any necessity.

Wave_Art. 8014 536 14L G
Tavolo fisso con piano sagomato in legno noce canaletto, base stampata in Baydur laccata beige lucido.
Fixed table with profiled wooden top in canaletto walnut, base in lacquered Glossy beige Baydur.

Aragona_Art. 7209 14 TV51
Sedia finitura noce canaletto rivestita in tessuto Verbena fango.
Chair finished in canaletto walnut and covered in Verbena mud fabric.



WAVE

design by Studio 28

Wave_Art. 8014N 501 V101G
Tavolo allungabile con binario in alluminio anodizzato, base stampata in Baydur laccata bianco lucido e piano in vetro extrachiaro temperato bianco.

Extensible table with anodized aluminium mechanism, base in lacquered Glossy white Baydur and top in tempered extraclear white glass.

Vivienne_Art. 7258 P1
Sedia rivestita in pelle bianca.
Chair covered in white leather.

WAVE

design by Studio 28

Wave_Art. 8014 560 V81ER
Tavolo fisso con base stampata in Baydur
laccata champagne lucido e piano
ellittico in vetro temperato trasparente.
*Fixed table with base in lacquered Glossy
champagne Baydur and elliptical top in
tempered transparent glass.*

Charm_Art. 7216 P70
Sedia interamente rivestita in pelle testa
di moro.
Chair covered in dark brown leather.

WAVE

design by Studio 28

TAVOLI FISSI_PIANI IN VETRO FIXED TABLES_GLASS TOPS

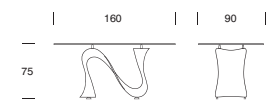

(FP) art. 8014

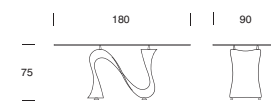

(FA) art. 8014

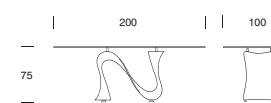

(FG) art. 8014

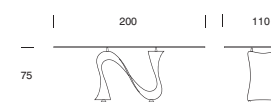

(FD) art. 8014

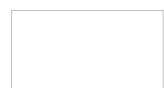

TAVOLI FISSI_PIANI ELLITTICI VETRO TRASPARENTE FIXED TABLES_ELLIPTICAL GLASS TRANSPARENT TOP

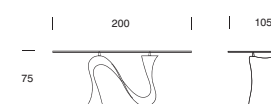

(EL) art. 8014



(ER) art. 8014



TAVOLI ALLUNGABILI_PIANI IN VETRO EXTENDIBLE TABLES_GLASS TOPS

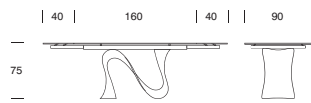

(P) art. 8014

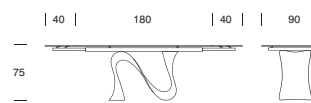

(A) art. 8014

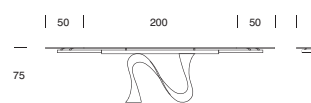

(G) art. 8014

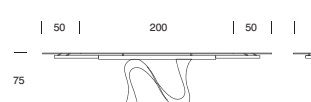

(D) art. 8014



TAVOLI FISSI_PIANI SAGOMATI LEGNO O MARMO FIXED TABLES_WOOD OR MARBLE PROFILED TOPS

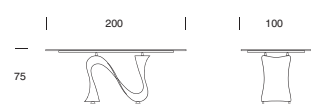

(A) art. 8014

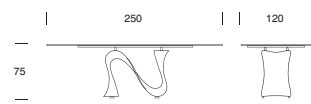

(G) art. 8014



FINITURE BASE STRUCTURE FINISHING



FINITURE PIANI IN VETRO DI SERIE GLASS TOPS RECTANGULAR STANDARD FINISHING

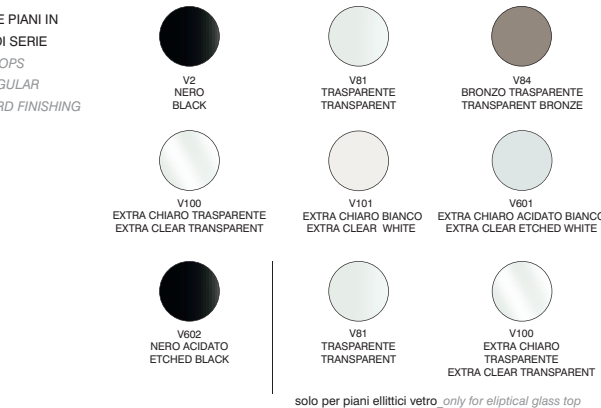

FINITURE PIANI RETTANGOLARI IN VETRO SU ORDINAZIONE TOP RECTANGULAR FINISHING IN CUSTOM GLASS

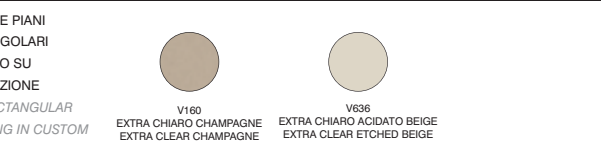

FINITURE PIANI SAGOMATI LEGNO WOODEN PROFILED TOP FINISHING



FINITURE PIANI SAGOMATI IN MARMO MARBLE PROFILED TOP FINISHING



FINITURE BINARIO PER PIANI ALLUNGABILI MECHANISM FINISHING FOR EXTENDIBLE TOPS



NOTA: distanziale per appoggio piani fissi, solo in finitura 71 alluminio brillantato
NOTE: for fixed tops, spacer support available only in 71 polished aluminium finishing



Scegli il tuo RAL preferito...

Choose your favourite RAL...

Wave_Art. 8014 RAL1027 V81ER

Tavolo fisso con base stampata in Baydur laccata RAL 1027 giallo curry lucido e piano ellittico in vetro temperato trasparente.

Fixed table with base in lacquered RAL 1027 glossy yellow curry Baydur and elliptic top in transparent tempered glass.

Wave_Art. 8014 RAL3012 V81ER

Tavolo fisso con base stampata in Baydur laccata RAL 3012 beige rosato lucido e piano ellittico in vetro temperato trasparente.

Fixed table with base in lacquered RAL 3012 glossy pink beige Baydur and elliptic top in transparent tempered glass.

Wave_Art. 8014 RAL3004 V81ER

Tavolo fisso con base stampata in Baydur laccata RAL 3004 rosso porpora lucido e piano ellittico in vetro temperato trasparente.

Fixed table with base in lacquered RAL 3004 glossy crimson red Baydur and elliptic top in transparent tempered glass.

Wave_Art. 8014 RAL7006 V81ER

Tavolo fisso con base stampata in Baydur laccata RAL 7006 grigio beige lucido e piano ellittico in vetro temperato trasparente.

Fixed table with base in lacquered RAL 7006 glossy grey beige Baydur and elliptic top in transparent tempered glass.

TOKYO

design by Studio 28

TAVOLO TOKYO ART. T6951 P/A/G/FP/FA/FG/LA/LG/LZ

*Tavolo fisso o allungabile con binario in alluminio e piano in vetro temperato, legno o marmo.
Base in agglomerato di marmo disponibile in finitura RAL per creare una sala da pranzo personalizzata.
Infinite combinazioni rendono questo tavolo unico ed inimitabile, un must decisamente senza tempo.*

*Fixed or extendible table with aluminium track guide mechanism, top in tempered glass, wood or marble.
Base in marble agglomerate available in any RAL finishing in order to create your own customized dining room.
Endless combinations make this table unique and inimitable, a timeless must.*



Tokyo Art. 6951 501 M1G
Tavolo fisso con base in agglomerato di marmo
e piano in marmo bianco opaco di Carrara.
*Fixed table with base in marble agglomerate and
top in matt white Carrara marble.*

TOKYO

design by Studio 28

Tokyo_Art. 6951 501 M1G

Tavolo fisso con base in agglomerato di marmo e piano in marmo opaco bianco di Carrara.

Fixed table with base in marble agglomerate and top in matt white Carrara marble.

Ginza_Art. 7275 K51

Sedia a slitta in cuoio fango.

Sleigh chair in mud thick leather.

TOKYO

design by Studio 28

Tokyo_Art. 6951B RAL 7006 V84A

Tavolo allungabile con binario in alluminio brillantato, base in agglomerato di marmo RAL grigio beige e piano in vetro temperato bronzato trasparente.

Extendible table with polished aluminium mechanism, base in RAL grey beige marble agglomerate and top in tempered bronzed transparent glass.

Charm_Art.7216 S70/S51

Sedia interamente rivestita in ecopelle testa di moro/fango.

Chair entirely covered in dark brown/mud eco-leather.

Granada_Art.8603H 14 V84A

Madia 3 ante e 3 cassetti in noce canaletto e vetro acidato bronze serigrafato.

Sideboard with 3 doors and 3 drawers in canaletto walnut and etched bronzed glass with serigraphy.

TOKYO

design by **Studio 28**

Tokyo_Art. 6951 502 14LZ
Tavolo fisso con base in agglomerato di
marmo laccato nero lucido e piano in legno
noce canaletto.

*Fixed table with base in lacquered glossy
black marble agglomerate and top in
canaletto walnut.*

Mivida_Art. 7212 14 PF47
Sedia finitura noce canaletto e rivestita in
pelle fiore cipria.

*Chair in canaletto walnut finish, covered in
powder grain leather.*



*Tokyo è il simbolo della Tonin Casa, il simbolo del
vero Made in Italy 100%. Materie prime italiane,
design italiano, produzione italiana.*

*Tokyo is the symbol of Tonin Casa, the symbol of true
100% Made in Italy. Italian prime materials, Italian
design, Italian production.*

TOKYO

design by Studio 28



Tokyo_Art. 6951N 501 V601FA
Tavolo fisso con base in agglomerato di marmo laccato bianco lucido e piano in vetro temperato extrachiaro acidato bianco.
Fixed table with in base lacquered glossy white marble agglomerate and top in tempered extraclear etched white glass.

Deira_Art. 7278 K01
Sedia in cuoio bianco.
Chair in white thick leather.

TOKYO

design by Studio 28

TAVOLI FISSI_PIANI IN VETRO FIXED TABLES_GLASS TOPS

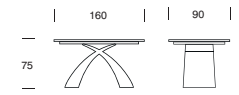

(FP) art. 6951

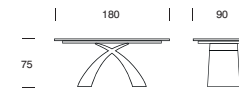

(FA) art. 6951

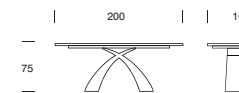

(FG) art. 6951



TAVOLI FISSI_PIANI SAGOMATI LEGNO O MARMO FIXED TABLES_WOOD OR MARBLE PROFILED TOPS

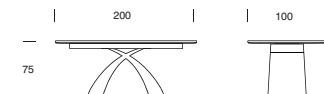

(A) art. 6951

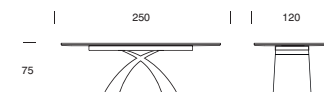

(G) art. 6951



TAVOLI ALLUNGABILI_PIANI IN VETRO EXTENDIBLE TABLES_GLASS TOPS

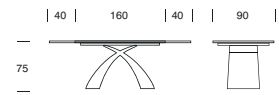

(P) art. 6951

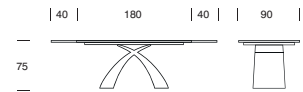

(A) art. 6951

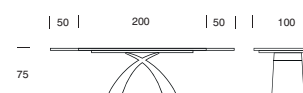

(G) art. 6951



FINITURE BASE BASE FINISHING

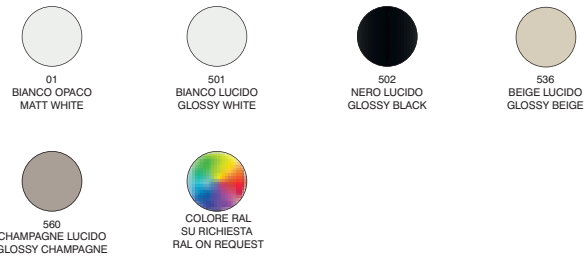

FINITURE PIANI IN VETRO DI SERIE GLASS TOPS STANDARD FINISHING

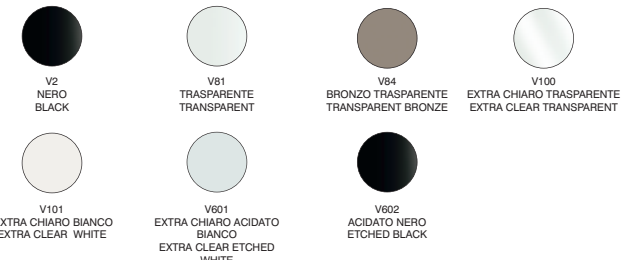

FINITURE PIANI IN VETRO SU ORDINAZIONE TOP FINISHING IN CUSTOM GLASS



FINITURE PIANI SAGOMATI LEGNO WOODEN PROFILED TOP FINISHING



FINITURE PIANI SAGOMATI IN MARMO MARBLE PROFILED TOP FINISHING



FINITURE BINARIO PER PIANI VETRO FISSI E ALLUNGABILI MECHANISM FINISHING FOR GLASS TOPS EXTENDIBLE AND FIXED



FINITURE BINARIO PER PIANI SAGOMATI LEGNO E MARMO MECHANISM FINISHING FOR PROFILED WOOD AND MARBLE TOPS

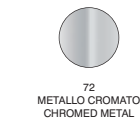

Tokyo_Art. 6951B 501 V81A

Tavolo allungabile con binario in alluminio brillantato, base in agglomerato di marmo laccato bianco e piano in vetro temperato trasparente.

Extendible table with polished aluminium mechanism, base in lacquered white marble agglomerate and top in tempered transparent glass.

BUTTERFLY

design by Angelo Tomaiuolo

TAVOLO BUTTERFLY ART. T8070 T/P/A/G

*Tavolo fisso o allungabile con binario in alluminio e piani in vetro, legno o nelle finiture di marmo più pregiate;
il tutto sostenuto da una base realizzata in multistrato termo curvato e rivestito noce canaletto o rovere scuro.
Il disegno audace delle basi si amalgama con la classicità del vetro o del marmo per riscoprire un tavolo dal design inimitabile.
Disponibile in diverse dimensioni e finiture.*

*Fixed or extendible table with aluminium track guide mechanism, top available in glass, wood or in the finest marble finishing;
the base is made in a thermo curved multilayer and veneered with canaletto walnut or dark oak.
The audacious design of the bases blends with the classicity of glass or marble to uncover a table with an inimitable design.
Available in different dimensions and finishing.*



Mivida_Art. 7212 17 PN5
Sedia con struttura in rovere naturale e rivestimento in pelle nabuk panna.
Chair with structure in natural oak and covered in cream nabuk leather.

Butterfly_Art. 8070 01 17 LG
Tavolo fisso con gambe in legno curvato laccato bianco e piano sagomato in rovere naturale.
Fixed table with legs in lacquered white curved wood and profiled top in natural oak.

BUTTERFLY

design by Angelo Tomaiuolo

L'eleganza abbinata alla praticità. Butterfly infatti è anche disponibile nella versione allungabile.

Elegance combined with practicality. Butterfly is also available in the extendible version.



Butterfly_Art. 8070N 01 V601G
Tavolo allungabile con binario in alluminio anodizzato, gambe in legno curvato laccato bianco e piano in vetro temperato extrachiaro acidato bianco.

Extendible table with mechanism in anodized aluminium, legs in curved wood lacquered white and top in tempered extraclear etched white glass.

Simply_Art. 7206 KN32
Sedia in cuoio nuvolato naturale.

Chair in naturally clouded thick leather.

BUTTERFLY

design by Angelo Tomaiuolo



Butterfly_Art. 8070 14 M1A

Tavolo fisso con gambe in legno curvato noce canaletto e piano in marmo bianco opaco di Carrara.
Fixed table with wooden legs in curved canaletto walnut and top in matt white Carrara marble.

Lisetta_Art. 7200 P35

Sedia interamente rivestita in pelle salvia.
Chair entirely covered in sage leather.

Honey_Art. 6112 14 02

Madia 3 ante in legno con elementi noce canaletto.
Sideboard 3 doors in wood with canaletto walnut elements.

Skin_Art. 7530 V184

Composizione di specchi bronze.
Composition of bronzed mirrors.



BUTTERFLY

design by Angelo Tomaiuolo

TAVOLI FISSI_PIANI SAGOMATI VETRO,
LEGNO, MARMO
FIXED TABLES_PROFILED TOP IN GLASS, WOOD
OR MARBLE

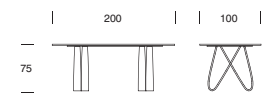

(A) art. 8070

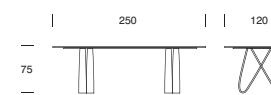

(G) art. 8070



(P) art. 8070

TAVOLI FISSI_PIANI VETRO E MARMO
FIXED TABLES_TOPS IN GLASS, OR
MARBLE

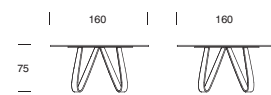

(T) art. 8070

TAVOLI ALLUNGABILI_PIANI RETTANGOLARI
VETRO
EXTENDABLE TABLES GLASS RECTANGULAR TOPS

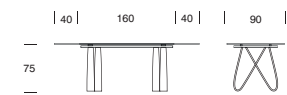

(P) art. 8070v

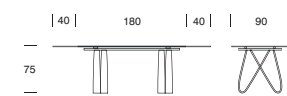

(A) art. 8070v

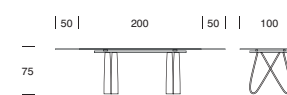

(G) art. 8070v

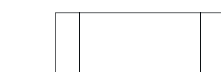

FINITURE
BASE
BASE
FINISHING



01
BIANCO OPACO
MATT WHITE



14
NOCE CANALETTO
CANALETTO WALNUT



16
ROVERE SCURO
TERMOTRATTATO
DARK OAK HEATTREATED

FINITURE PIANI
IN VETRO DI
SERIE
GLASS TOP
STANDARD
FINISHING



V2
NERO
BLACK



V101
EXTRA CHIARO BIANCO
EXTRA CLEAR WHITE



V601
EXTRA CHIARO
ACIDATO BIANCO
EXTRA CLEAR
ETCHED WHITE



V602
ACIDATO NERO
ETCHED BLACK

FINITURE PIANI
IN VETRO SU
ORDINAZIONE
TOP FINISHING
IN CUSTOM
GLASS



V636
EXTRA CHIARO
ACIDATO BEIGE
EXTRA CLEAR
ETCHED BEIGE

FINITURE
PIANI IN LEGNO
SAGOMATI
WOODEN PROFILED
TOP
FINISHING



01
BIANCO OPACO
MATT WHITE



14
NOCE CANALETTO
CANALETTO WALNUT



16
ROVERE SCURO
TERMOTRATTATO
DARK OAK HEATTREATED



17
ROVERE NATURALE
NATURAL OAK

FINITURE
PIANI IN MARMO
SAGOMATI
MARBLE PROFILED TOP
STANDARD FINISHING



MA01
BIANCO CARRARA OPACO
MATT WHITE CARRARA



MA02
NERO MARQUINA OPACO
MATT BLACK MARQUINA



MA09
MARMO GRIGIO OPACO
MATT GREY MARBLE



M101
BIANCO CARRARA LUCIDO
GLOSSY WHITE CARRARA



M102
NERO MARQUINA LUCIDO
GLOSSY BLACK MARQUINA



M129
MARMO GRIGIO LUCIDO
GLOSSY GREY MARBLE

FINITURE BINARIO
PER PIANI
ALLUNGABILI
MECHANISM
FINISHING FOR
EXTENDIBLE AND
FIXED TOPS



32
ALLUMINIO ANODIZZATO
ANODIZED ALUMINIUM



71
ALLUMINIO BRILLANTATO
POLISHED ALUMINIUM

Butterfly è sinonimo di cura per i dettagli. Una base di design da adattare ad infinite tipologie di piani; da quelli più pregiati in marmo o legno a quelli in vetro.

Butterfly is synonymous for attention to detail. A design base which adapts to infinite types of tops; from the most precious in marble or wood to those in glass.



Butterfly_Art. 8070 14 V101P

Tavolo fisso con gambe in legno curvato noce canaletto e piano in vetro temperato extra chiaro bianco.

Fixed table with wooden curved canaletto walnut legs and top in tempered extraclear white glass.

Charm_Art. 7216 S60

Sedia interamente rivestita in ecopelle tortora

Chair entirely covered in dove eco-leather.

BROOKLYN

design by **Studio 28**

TAVOLO BROOKLYN ART. T8000 P/A/G/FP/FA/FG

*Tavolo fisso o allungabile con binario in alluminio, piano e allunghe in vetro temperato.
Basi realizzate in MDF laccato, rivestite legno o cuoio. Brooklyn può essere personalizzato per avere un tavolo giovane e stiloso
oppure più elegante e raffinato mantenendo sempre costante la qualità. Disponibile in diverse dimensioni e finiture.*

*Fixed or extendible table with aluminium track guide mechanism, top and extensions in tempered glass.
Bases in lacquered MDF, wood veneer or leather. Brooklyn can be customized to give you either a young and stylish or
a more elegant and refined table, whilst maintaining a constant quality. Available in different dimensions and finishing.*



Brooklyn_Art. 8000B 17 V101 FA
Tavolo fisso in rovere naturale e piano
in vetro temperato extrachiaro bianco.
*Fixed table in natural oak and top in
tempered extraclear white glass.*

Madeleine_Art. 7276 K01
Sedia in vero cuoio bianco con cuciture in tinta.
*Chair in genuine thick leather with in matching
stitching.*

BROOKLYN

design by Studio 28

Ampia selezione di vetri, di legni e di dimensioni e forme geometriche intramontabili sono gli ingredienti del tavolo Brooklyn.

Wide selection of glass tops, wooden bases and timeless geometric forms are the ingredients of the Brooklyn table.



Brooklyn_Art. 8000N 16 V636G
Tavolo allungabile con base in rovere scuro termotrattato, binario in alluminio anodizzato e piano in vetro temperato acidato beige.

Extendible table with base in thermo treated dark oak, anodized aluminium mechanism and top in tempered etched beige glass.

Aragona_Art.7209 16 PN51
Sedia con struttura in finitura rovere scuro termotrattato e rivestita in nabuk fango.
Chair finished in dark oak thermo treated and covered in mud nabuk.

BROOKLYN

design by Studio 28



Brooklyn_Art. 8000B 14 V84A
Tavolo allungabile con base in noce canaletto, binario in alluminio brillantato e piano in vetro temperato bronzato trasparente.

Extendible table with base in canaletto walnut, with polished aluminium mechanism and top in tempered bronzed transparent glass.

Stella_Art.7263 S60
Sedia impilabile rivestita in ecopelle tortora con struttura cromo.

Stackable chair covered in dove eco-leather.

BROOKLYN

design by Studio 28

TAVOLI FISSI_PIANI VETRO FIXED TABLES_GLASS TOPS

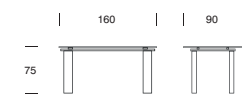

(FP) art. 8000

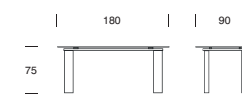

(FA) art. 8000

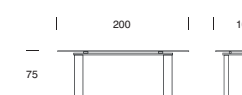

(FG) art. 8000

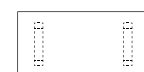

TAVOLI ALLUNGABILI_PIANI VETRO EXTENDIBLE TABLES_GLASS TOPS

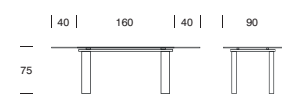

(P) art. 8000

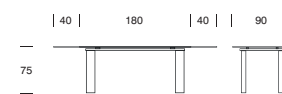

(A) art. 8000

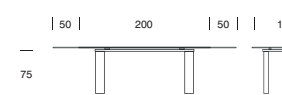

(G) art. 8000

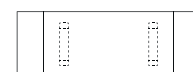

FINITURE BASE BASE FINISHING

PER IL CAMPIONARIO
COMPLETO VEDI LE PAGINE
FINALI
FOR COMPLETE SAMPLES SEE
THE FINAL PAGES



FINITURE PIANI IN VETRO DI SERIE

GLASS TOPS
STANDARD
FINISHING

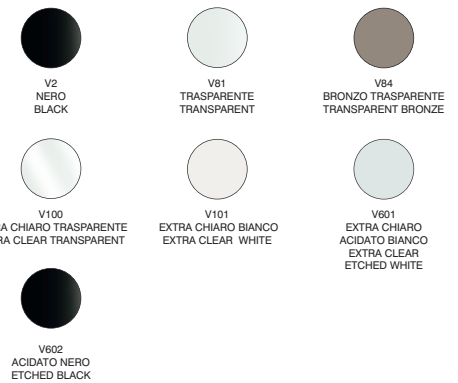

FINITURE PIANI IN VETRO SU ORDINAZIONE

TOPS FINISHING
IN CUSTOM GLASS



FINITURE BINARIO PER PIANI FISSI E ALLUNGABILI

MECHANISM FINISHING
FOR
EXTENDIBLE AND FIXED
TOPS



Brooklyn_Art. 8000N 01 V81G
Tavolo allungabile con base laccata bianca, binario in alluminio
anodizzato e piano in vetro temperato trasparente.
Extendible table with lacquered white base, anodized aluminium
mechanism and top in tempered transparent glass.

ROMA

design by **Angelo Tomaiuolo**

TAVOLO ROMA ART. T8068 P/A/FP/FA

*Tavolo fisso o allungabile con piano in legno e base in marmo o legno.
Nella versione allungabile il meccanismo di allunga è molto semplice e determina l'estrema praticità ed eleganza del tavolo.
La combinazione di due materiali estremamente pregiati da vita ad un tavolo essenziale ma di grande carattere.
Disponibile in diverse dimensioni e finiture.*

*Fixed or extendible table with wooden top and base in marble or wood .
In the extendible version the mechanism is very simple and gives the table practicality and elegance.
The combination of two valuable and refined materials create a table which is essential but with attitude.
Available in different dimensions and finishing.*



Roma_Art. 8068F 17 17P
Tavolo fisso con gambe e piano in legno rovere naturale.
Fixed table with legs and top in natural oak.

Aragona_Art. 7209 17 TV01
Sedia con struttura in rovere naturale e rivestimento in tessuto Verbena bianco.
Chair with structure in natural oak covered in white Verbena fabric.

ROMA

design by **Angelo Tomaiuolo**

Roma_Art. 8068 M1 16A

Tavolo allungabile con gambe in marmo bianco di Carrara e piano in rovere scuro termotrattato.

Extendible table with legs in white Carrara marble and top in dark thermo treated oak.

Mivida_Art. 7212 16 PF18

Sedia finitura rovere scuro termotrattato e rivestita in pelle fiore sabbia.

Chair finished in dark oak thermo treated and covered in sand grain leather.

Granada_Art.8602 16 V84A

Madia 4 ante in rovere scuro e vetro acidato bronze serigrafato.

Sideboard 4 doors in dark oak and etched bronzed glass with serigraphy.

Tonin Casa non lascia nulla al caso, infatti seleziona solo i marmi con la venatura migliore per adattarli a piani in legno curati in ogni minimo particolare.

Tonin Casa leaves nothing to chance, selecting only marble with the best grain to adapt it to wooden tops finished in every detail.



ROMA

design by **Angelo Tomaiuolo**



TAVOLI FISSI_PIANI IN LEGNO FIXED TABLES_WOODEN TOPS

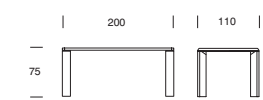

(P) art. 8068F

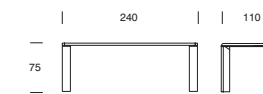

(A) art. 8068F

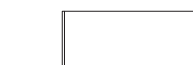

TAVOLI ALLUNGABILI_PIANI IN LEGNO EXTENDIBLE TABLES_WOODEN TOPS

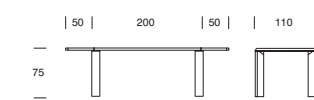

(P) art. 8068

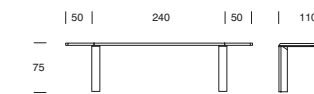

(A) art. 8068

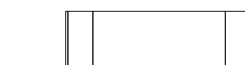

FINITURE BASE LEGNO WOOD BASE FINISHING



01
BIANCO OPACO
MATT WHITE



14
NOCE CANALETTO
CANALETTO WALNUT



16
ROVERE SCURO
TERMOTRATTATO
DARK OAK HEATTREATED



17
ROVERE NATURALE
NATURAL OAK

FINITURE BASE MARMO MARBLE BASE FINISHING



MA01
BIANCO CARRARA OPACO
MATT WHITE CARRARA



MA02
MARMO GRIGIO OPACO
MATT GREY MARBLE

FINITURE PIANI E ALLUNGHE LEGNO WOODEN TOP AND EXTENSION FINISHING



01
BIANCO OPACO
MATT WHITE



14
NOCE CANALETTO
CANALETTO WALNUT



16
ROVERE SCURO TERMOTRATTATO
DARK OAK HEATTREATED



17
ROVERE NATURALE
NATURAL OAK



Roma_Art. 8068 M1 16A
Tavolo allungabile con gambe in marmo bianco di Carrara e piano in rovere scuro termotrattato.
Extendible table with legs in white Carrara marble and top in dark thermo treated oak.

ALBA

design by **Studio Tonin Creatives**

TAVOLO ALBA ART. T8006

*Tavolo allungabile con struttura in alluminio verniciato, piano e allunghe in vetro temperato acidato.
Il dettaglio lo fa il meccanismo automatico di apertura che permette con un semplice gesto di ottenere un tavolo di ben 3 metri.
Design minimal e perfezione tecnica sono le caratteristiche salienti di questo articolo.*

*Fixed or extendible table with aluminium track guide mechanism, top in etched tempered glass.
The main feature of this table is the automatic opening mechanism that enables, with one simple movement,
to obtain a 3 mt table top! A minimalistic design and technical perfection are the main peculiarities of this article.*



Alba_Art. 8006 01 V601
Tavolo allungabile con struttura in alluminio laccato bianco e piano in vetro temperato extra chiaro acidato bianco.
Extendible table with structure in white lacquered aluminium and top in tempered extraclear etched glass.

Giudecca_Art. 7267 P29
Sedia interamente rivestita in pelle grigio gabbiano.
Chair entirely covered in grey gull leather.

ALBA

design by **Studio Tonin Creatives**

Alba rappresenta il massimo della tecnologia grazie al suo sofisticato meccanismo di apertura. Finiture matt lo rendono invece un tavolo assolutamente "di moda".

Alba represents the maximum in technology thanks to its sophisticated opening mechanism. Matt finishing make it an absolutely fashionable table.



Alba_Art. T8006 02 V602
Tavolo allungabile con struttura in alluminio laccato nero e piano in vetro temperato acidato nero.
Extendible table with structure in black lacquered aluminium and top in tempered black etched glass.

Mivida_Art. 7212 14 PF47
Sedia finitura noce canaletto e rivestita in pelle fiore cipria.
Chair in canaletto walnut and covered in powder grain leather.

Mivida_Art. 7213 14 PF4
Poltrona finitura noce canaletto e rivestita pelle fiore gialla.
Armchair in canaletto walnut and covered in yellow grain leather.

ALBA

design by **Studio Tonin Creatives**



Alba Art. T8006 01 V601

Tavolo allungabile con struttura in alluminio laccato bianco e piano in vetro temperato extrachiaro acidato bianco.

Extendible table with structure in lacquered white aluminium and top in tempered extraclear etched white glass.



TAVOLI ALLUNGABILI_PIANI IN VETRO EXTENDIBLE TABLES_GLASS TOPS

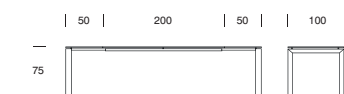

ART. T8006

FINITURE
STRUTTURA
BASE
FINISHING



01
BIANCO OPACO
MATT WHITE



02
NERO OPACO
MATT BLACK

FINITURE
PIANI
IN VETRO
GLASS TOP
FINISHING



V2
NERO
BLACK



V101
EXTRA CHIARO BIANCO
EXTRA CLEAR WHITE



V601
EXTRA CHIARO ACIDATO
BIANCO
EXTRA CLEAR ETCHED WHITE



V602
ACIDATO NERO
ETCHED BLACK

ARCOS

design by **Studio 28**

TAVOLO ARCOS ART. T8050 P/A/G/D

*Tavolo allungabile con binario in alluminio, piano e allunghe in vetro temperato;
struttura in acciaio cromato o rivestita legno per il massimo della qualità e del design italiano.
Arcos è sinonimo di semplicità e di perfezione tecnica per un tavolo che arreda senza tempo.
Disponibile in diverse dimensioni e finiture.*

*Fixed or extendible table with aluminium track guide mechanism, top and extensions in tempered glass;
structure in chromed steel or wood veneered to give you the best in quality and Italian design. Arcos stands for simplicity
and technical perfection, to create a table with a timeless feel. Available in various dimensions and finishing.*



Arcos_Art. 8050C 01 V100G
Tavolo allungabile con binario e base in
alluminio laccato bianco.
Piano in vetro temperato extrachiaro
trasparente.

*Extendible table with mechanism and
base in lacquered white aluminium.
Top in tempered extraclear transparent
glass.*

Plaza_Art. 7299 K60
Sedia interamente rivestita in cuoio
marrone chiaro.
*Chair entirely covered in light brown thick
leather.*

ARCOS

design by Studio 28

Arcos_Art. 8050B 14 V2A

Tavolo allungabile con binario in alluminio
brillantato e gambe in alluminio rivestite
noce canaletto. Piano in vetro temperato nero.
*Extendible table with anodized aluminium
mechanism and legs in aluminium covered
canaletto walnut. Top in tempered black glass.*

Aragona_Art.7209 14 TV51

Sedia finitura noce canaletto rivestita in
tessuto Verbena fango.
*Chair finished in canaletto walnut and covered
in Verbena fabric mud colour.*

ARCOS

design by Studio 28

TAVOLI ALLUNGABILI PIANI VETRO EXTENDIBLE TABLES GLASS TOPS

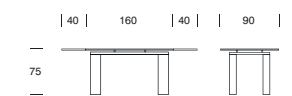

(P) art. 8050

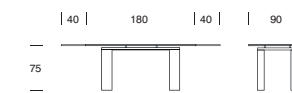

(A) art. 8050

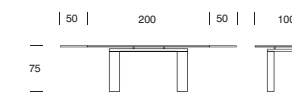

(G) art. 8050

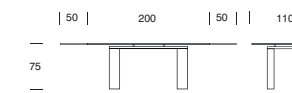

(D) art. 8050

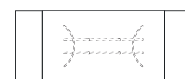

FINITURE BASE BASE FINISHING



01
BIANCO OPACO
MATT WHITE



14
NOCE CANALETTO
CANALETTO WALNUT



71
ALLUMINIO BRILLANTATO
POLISHED ALUMINIUM

FINITURE PIANI IN VETRO DI SERIE GLASS TOP STANDARD FINISHING



V2
NERO
BLACK



V81
TRASPARENTE
TRANSPARENT



V84
BRONZO TRASPARENTE
TRANSPARENT BRONZE



V100
EXTRA CHIARO TRASPARENTE
EXTRA CLEAR TRANSPARENT



V101
EXTRA CHIARO BIANCO
EXTRA CLEAR WHITE



V801
EXTRA CHIARO
ACIDATO BIANCO
EXTRA CLEAR
ETCHED WHITE



V802
ACIDATO NERO
ETCHED BLACK

FINITURE PIANI IN VETRO SU ORDINAZIONE TOP FINISHING IN CUSTOM GLASS



V180
EXTRA CHIARO CHAMPAGNE
EXTRA CLEAR CHAMPAGNE



V636
EXTRA CHIARO
ACIDATO BEIGE
EXTRA CLEAR
ETCHED BEIGE

FINITURE BINARIO MECHANISM FINISHING



01
ALLUMINIO VERNICIATO BIANCO
OPACO
MATT WHITE LACQUERED
ALUMINIUM



32
ALLUMINIO ANODIZZATO
ANODIZED ALUMINIUM



71
ALLUMINIO BRILLANTATO
POLISHED ALUMINIUM

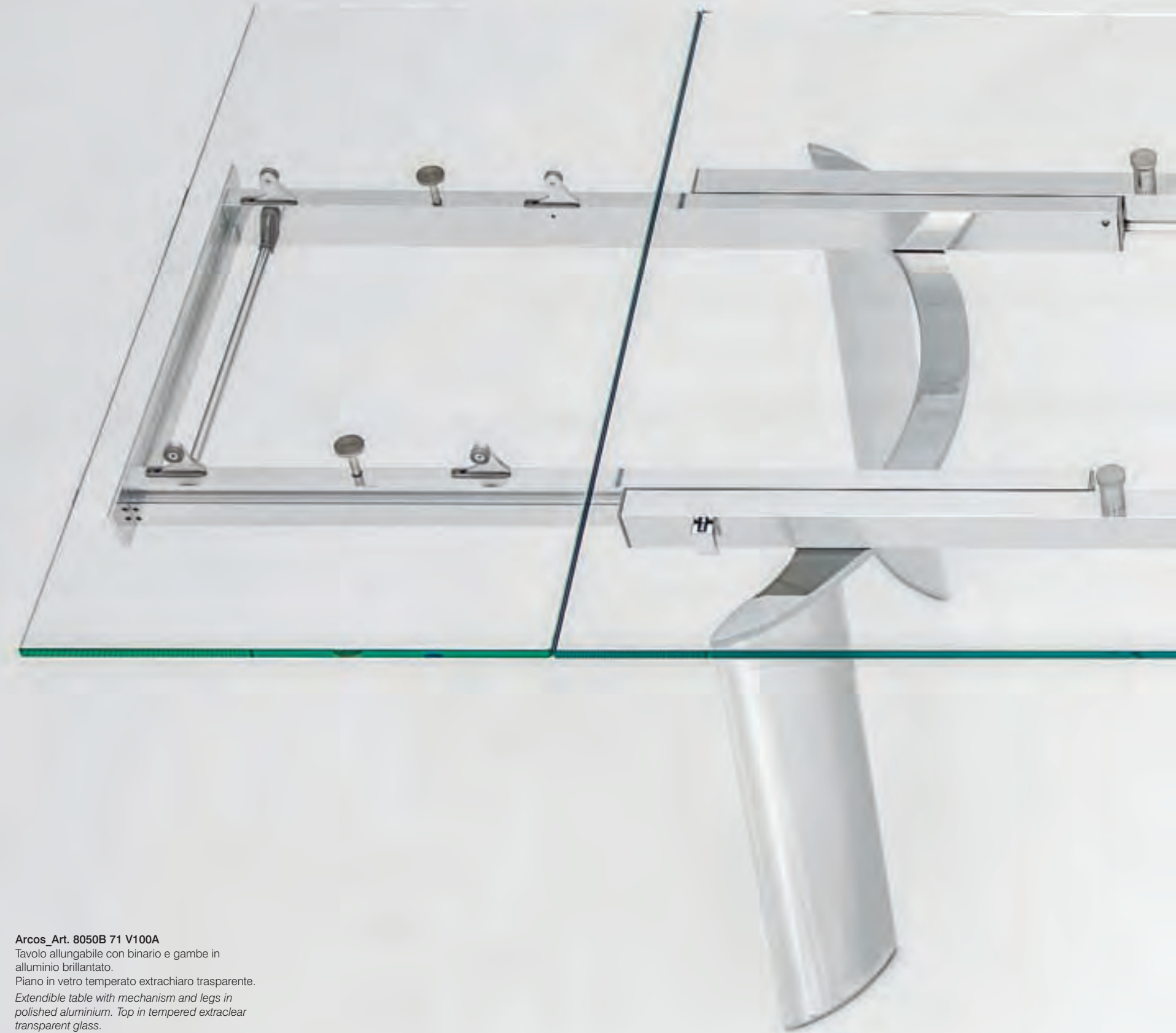

Arcos_Art. 8050B 71 V100A

Tavolo allungabile con binario e gambe in alluminio brillantato.

Piano in vetro temperato extrachiaro trasparente.
Extendible table with mechanism and legs in polished aluminium. Top in tempered extraclear transparent glass.

MANHATTAN

design by **Studio 28**

TAVOLO MANHATTAN ART. T8051 P/A/G/D

Tavolo fisso o allungabile con binario in alluminio, piano in vetro temperato, legno o marmo; struttura in acciaio cromato o laccata bianca. Cura nei dettagli e nella scelta della materia prima per garantire un prodotto che solo il vero made in Italy può generare.

Fixed or extendible table with aluminium track guide mechanism, top in tempered glass, wood or marble; structure in chromed steel or lacquered white. Care for details and in choosing raw materials to guarantee a product that only the real Made in Italy can create.



Manhattan_Art. 8051 72 14LG

Tavolo fisso con base in metallo cromato e piano in legno noce canaletto.

Fixed table with base in chromed metal and top in canaletto walnut.

Vivienne_Art. 7258 PF65

Sedia rivestita in pelle fiore rosso mattone.

Chair covered in brick red grain leather.

Granada_Art. 8613 14 V84B LS

Vetrina in noce canaletto con ante in vetro bronzato trasparente e serigrafato. Maniglie Swarovski® e luce led interna.

Showcase in canaletto walnut with doors in bronzed transparent glass with serigraphy. Knobs in Swarovski® and internal LED lighting.



MANHATTAN

design by Studio 28

Manhattan_Art. 8051 72 M102G
Tavolo fisso con base in metallo cromato e piano in marmo nero Marquina lucido.

Fixed table with base in chromed metal and top in glossy black Marquina marble.

Charonne_Art. 7265 P2
Sedia rivestita in pelle nera.

Chair covered in black leather.

MANHATTAN

design by Studio 28

*Un tavolo Tonin Casa è un tavolo per la vita;
Manhattan supporta solo meccanismi in alluminio,
vetri temperati e cromature eccellenti per garantire la
massima qualità nel tempo.*

*A Tonin Casa table is a table for life;
Manhattan supports only mechanisms in aluminium,
tempered glass and excellent chrome plating to guarantee the
maximum quality in time.*



Manhattan_Art. 8051B 72 V101G
Tavolo allungabile con binario in alluminio
brilliantato e base in metallo cromato.
Piano in vetro temperato extrachiaro bianco.
*Extendible table with polished aluminium
mechanism and base in chromed metal.
Top in tempered extraclear white glass.*

Sorbona_Art. 7295 P1
Sedia interamente rivestita in pelle bianca.
Chair entirely covered in white leather.

Venice_Art. 8253 01 V101
Madia con 4 ante in legno capitonné laccato
bianco opaco; top in vetro temperato
extrachiaro bianco e base in metallo cromato.
*Sideboard with 4 doors in capitonné matt white
lacquered wood; top in tempered extraclear
white glass and base in chromed metal.*

MANHATTAN

design by Studio 28

TAVOLI FISSI_PIANI SAGOMATI LEGNO E MARMO FIXED TABLES_WOOD AND MARBLE PROFILED TOPS

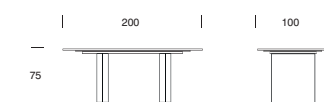

(A) art. 8051

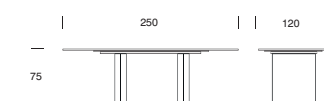

(G) art. 8051



TAVOLI ALLUNGABILI_PIANI IN VETRO EXTENDIBLE TABLES_GLASS TOPS

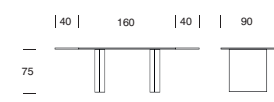

(P) art. 8051

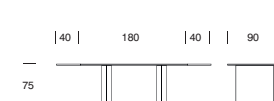

(A) art. 8051

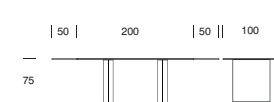

(G) art. 8051

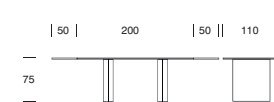

(D) art. 8051



FINITURE

BASE

BASE

FINISHING



01
BIANCO OPACO
MATT WHITE



72
METALLO
CROMATO
CHROMED METAL

FINITURE PIANI

IN VETRO DI SERIE

GLASS TOPS

STANDARD

FINISHING



V2
NERO
BLACK



V81
TRASPARENTE
TRANSPARENT



V84
BRONZO TRASPARENTE
TRANSPARENT BRONZE



V100
EXTRA CHIARO TRASPARENTE
EXTRA CLEAR TRANSPARENT



V101
EXTRA CHIARO BIANCO
EXTRA CLEAR WHITE



V801
EXTRA CHIARO
ACIDATO BIANCO
EXTRA CLEAR
ETCHED WHITE



V802
ACIDATO NERO
ETCHED BLACK

FINITURE PIANI

IN VETRO SU

ORDINAZIONE

TOP FINISHING

IN CUSTOM

GLASS



V160
EXTRA CHIARO CHAMPAGNE
EXTRA CLEAR CHAMPAGNE



V836
EXTRA CHIARO
ACIDATO BEIGE
EXTRA CLEAR
ETCHED BEIGE

FINITURE

PIANI SAGOMATI LEGNO

WOODEN PROFILED

TOP

FINISHING



01
BIANCO OPACO
MATT WHITE



14
NOCE CANALETTO
CANALETTO WALNUT



16
ROVERE SCURO
TERMOTRATTATO
DARK OAK HEATTREATED



17
ROVERE NATURALE
NATURAL OAK

FINITURE PIANI

IN MARMO DI SERIE

MARBLE TOPS

STANDARD FINISHING



MA01
BIANCO CARRARA OPACO
MATT WHITE CARRARA



MA02
NERO MARQUINA OPACO
MATT BLACK MARQUINA



MA29
MARMO GRIGIO OPACO
MATT GREY MARBLE



M101
BIANCO CARRARA LUCIDO
WHITE CARRARA GLOSSY



M102
NERO MARQUINA LUCIDO
BLACK MARQUINA GLOSSY



M129
MARMO GRIGIO LUCIDO
GREY MARBLE GLOSSY

FINITURE BINARIO

PER PIANI VETRO

ALLUNGABILI

MECHANISM FINISHING

EXTENDIBLE



01
BIANCO
WHITE



32
ALLUMINIO ANODIZZATO
ANODIZED ALUMINIUM



71
ALLUMINIO BRILLANTATO
POLISHED ALUMINIUM

FINITURE BINARIO PER

PIANI FISSI IN LEGNO E

MARMO

MECHANISM FINISHING

EXTENDIBLE WOOD AND

MARBLE



72
METALLO CROMATO
CHROMED METAL



Manhattan_Art. 8051 01 01 V100A

Tavolo allungabile con binario in alluminio laccato bianco e base laccato bianco opaco. Top in vetro temperato extrachiaro trasparente.

Extendible table with aluminium lacquered white mechanism and base lacquered in matt white. Top in tempered extraclear transparent glass.

CANNAREGIO

design by Studio 28

TAVOLO CANNAREGIO ART. T8017 P/A/G/FP/FA/FG

*Tavolo fisso o allungabile con binario in alluminio, piano e allunghe in vetro temperato;
Basi realizzate in alluminio unito a 45°, disponibili nella finitura brillantata, laccata bianca o rivestite noce canaletto.
Il massimo della qualità e dello stile racchiusi nell'eccellenza delle materie prime scelte per la realizzazione di questo tavolo.
Disponibile in diverse dimensioni e finiture.*

*Fixed or extendible table with aluminium track guide mechanism, top and extensions in tempered glass.
Bases in aluminium attached at a 45° angle, available in polished finish, lacquered in white or veneered canaletto walnut.
The utmost quality and style are all in the excellence of the raw materials chosen for this table.
Available in various dimensions and finishing.*

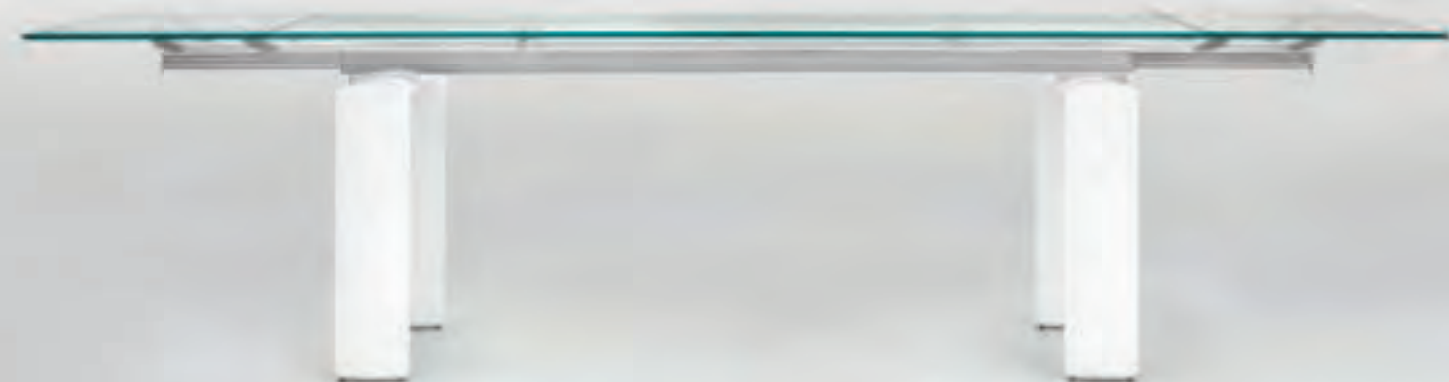

Cannaregio_Art. 8017B 14 V636G
Tavolo allungabile con binario in alluminio brillantato, base in alluminio rivestito noce canaletto e piano in vetro temperato extra chiaro acidato beige.

Extendible table with polished aluminium mechanism, base in aluminium covered canaletto walnut and top in tempered extraclear etched beige glass.

Vivienne_Art.7258 PF29
Sedia rivestita in pelle fiore grigio gabbiano.

Chair covered in gull grey grain leather.

CANNAREGIO

design by Studio 28



Cannaregio Art. 8017B 14 V636G

Tavolo allungabile con binario in alluminio brillantato, base in alluminio rivestito noce canaletto e piano in vetro temperato extra chiaro acidato beige.

Extendible table with polished aluminium mechanism, base in aluminium covered canaletto walnut and top in tempered extraclear etched beige glass.

Vivienne Art.7258 PF29

Sedia rivestita in pelle fiore grigio gabbiano.

Chair covered in gull grey grain leather.

CANNAREGIO

design by Studio 28

TAVOLI FISSI_PIANI IN VETRO FIXED TABLES_GLASS TOPS

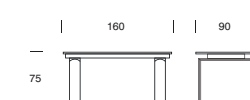

(FP) art. 8017

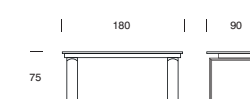

(FA) art. 8017

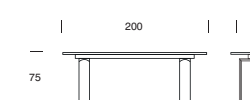

(FG) art. 8017

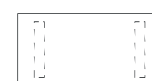

TAVOLI ALLUNGABILI_PIANI IN VETRO EXTENDIBLE TABLES_GLASS TOPS

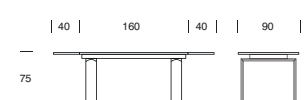

(P) art. 8017

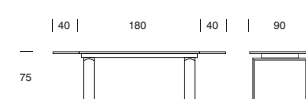

(A) art. 8017

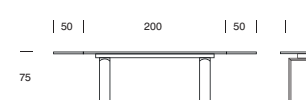

(G) art. 8017

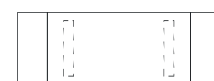

FINITURE BASE FINISHING



01
BIANCO OPACO
MATT WHITE



14
NOCE CANALETTO
CANALETTO WALNUT

FINITURE PIANI IN VETRO DI SERIE GLASS TOP STANDARD FINISHING



V2
NERO
BLACK



V81
TRASPARENTE
TRANSPARENT



V84
BRONZO TRASPARENTE
TRANSPARENT BRONZE



V100
EXTRA CHIARO TRASPARENTE
EXTRA CLEAR TRANSPARENT



V101
EXTRA CHIARO BIANCO
EXTRA CLEAR WHITE



V601
EXTRA CHIARO
ACIDATO BIANCO
EXTRA CLEAR
ETCHED WHITE



V602
ACIDATO NERO
ETCHED BLACK

FINITURE PIANI IN VETRO SU ORDINAZIONE TOP FINISHING IN CUSTOM GLASS



V160
EXTRA CHIARO CHAMPAGNE
EXTRA CLEAR CHAMPAGNE



V636
EXTRA CHIARO
ACIDATO BEIGE
EXTRA CLEAR
ETCHED BEIGE

FINITURE BINARIO PER PIANI FISSI E ALLUNGABILI MECHANISM FINISHING FOR EXTENDIBLE AND FIXED TOPS



32
ALLUMINIO ANODIZZATO
ANODIZED ALUMINIUM



71
ALLUMINIO BRILLANTATO
POLISHED ALUMINIUM



Cannaregio_Art. 8017B 01 V100G

Tavolo allungabile con binario in alluminio brillantato, base in alluminio laccata bianca e piano in vetro temperato extrachiaro trasparente.
Extendible table with polished aluminium mechanism, base in lacquered white aluminium and top in tempered extraclear transparent glass.

VENDÔME

design by Studio 28

TAVOLO VENDÔME ART. T8005 P/A/G/FP/FA/FG

*Tavolo fisso o allungabile, con binario in alluminio, piano e allunghe in vetro temperato.
Base in vetro curvato spessore 15 mm. La resistenza e l'eleganza del vetro sono gli ingredienti madre di questo tavolo.
Disponibile in diverse dimensioni e finiture.*

*Fixed or extendible table with aluminium track guide mechanism, top and extensions in tempered glass.
Base in 15mm thick curved glass. The resistance and elegance of glass are the main features of this table.
Available in different dimensions and finishing.*



Vendôme Art. 8005B C101 V101G
Tavolo allungabile con binario in alluminio
brillatato, base in vetro curvo extrachiaro
bianco e piano in vetro temperato
extrachiaro bianco.
*Extendible table with polished aluminium
mechanism, base in curved extraclear glass
and top in tempered extraclear white glass.*

VENDÔME

design by Studio 28

Vendôme_Art. 8005B C101 V101G
Tavolo allungabile con binario in alluminio
brillantato, base in vetro curvo extrachiaro bianco
e piano in vetro temperato extrachiaro bianco.
*Extendible table with polished aluminium
mechanism, base in curved extraclear white glass
and top in tempered extraclear white glass.*

Vivienne_Art.7258 PF6
Sedia rivestita in pelle fiore rosa.
Chair covered in pink grain leather.

Paris_Art.8355D 01 V101
Madia con 3 ante traforate e 3 cassetti in legno
laccato bianco opaco con vetro temperato
extrachiaro bianco.
*Sideboard with 3 fretted doors and 3 drawers
in lacquered matt white wood with tempered
extraclear white glass.*

VENDÔME

design by Studio 28

TAVOLI FISSI_PIANI IN VETRO FIXED TABLES_GLASS TOPS

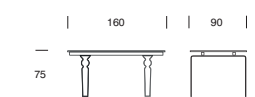

(FP) art. 8005

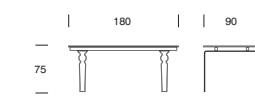

(FA) art. 8005

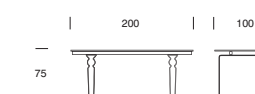

(FG) art. 8005



TAVOLI ALLUNGABILI_PIANI IN VETRO EXTENDIBLE TABLES_GLASS TOPS

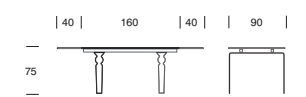

(P) art. 8005

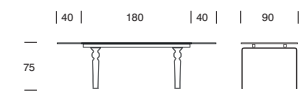

(A) art. 8005

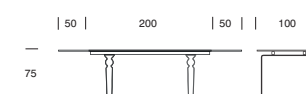

(G) art. 8005



FINITURE
BASE DI SERIE
BASES
STANDARD
FINISHING

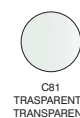

C81
TRASPARENTE
TRANSPARENT

FINITURE BASE
SU ORDINAZIONE
STRUCTURE
CUSTOM
FINISHING

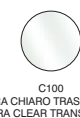

C100
EXTRA CHIARO TRASPARENTE
EXTRA CLEAR TRANSPARENT



C101
EXTRA CHIARO BIANCO
EXTRA CLEAR WHITE

FINITURE PIANI
IN VETRO DI
SERIE
GLASS TOPS
STANDARD
FINISHING



V81
TRASPARENTE
TRANSPARENT



V100
EXTRA CHIARO
TRASPARENTE
EXTRA CLEAR TRANSPARENT



V101
EXTRA CHIARO BIANCO
EXTRA CLEAR WHITE

FINITURE BINARIO PER
PIANI FISSI E ALLUNGABILI
MECHANISM FINISHING
FOR
EXTENDIBLE AND FIXED
TOPS



32
ALLUMINIO ANODIZZATO
ANODIZED ALUMINIUM



71
ALLUMINIO BRILLANTATO
POLISHED ALUMINIUM



Vendôme_Art. 8005B C100 V100A

Tavolo allungabile con binario in alluminio
brillantato, base in vetro curvo extrachiaro
trasparente e piano in vetro temperato
extrachiaro trasparente.

Extendible table with polished aluminium
mechanism, base in curved extraclear
transparent glass and top in tempered
extraclear transparent glass.

TEMPLE

design by Studio 28

TAVOLO TEMPLE ART. T8003 P/A/G/FP/FA/FG

*Tavolo fisso o allungabile con binario in alluminio e piano in vetro temperato.
Basamento realizzato in vetro curvo. Design intramontabile da adattare a tutte le situazioni domestiche.*

*Fixed or extendible table with aluminium mechanism and top in tempered glass.
Base in curved glass. A timeless design easily adapted to any domestic environment.*

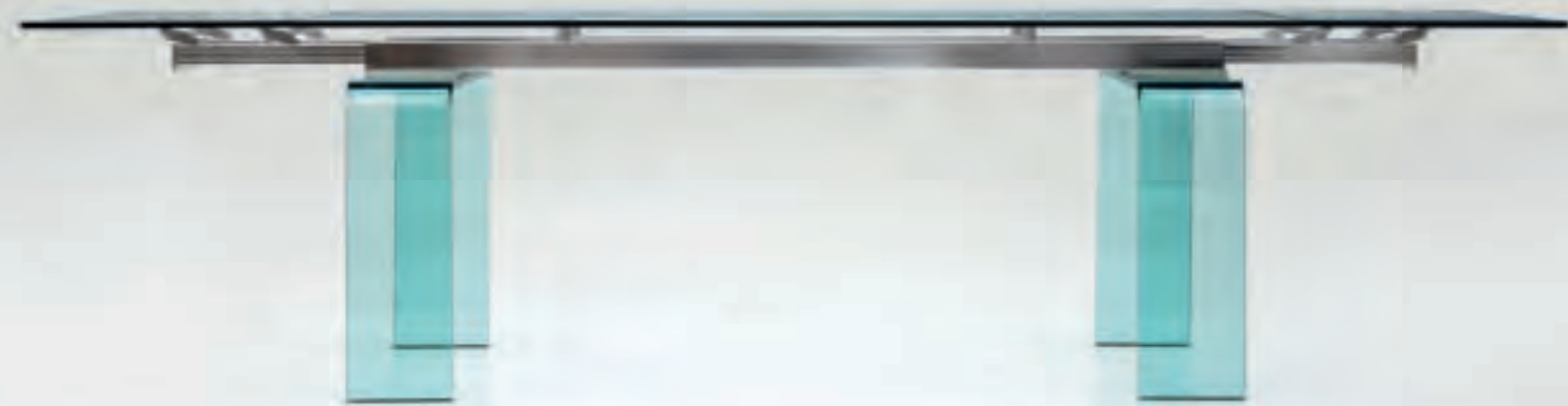

Temple Art. 8003B C81 V81A
Tavolo allungabile con binario in alluminio brillantato e base in vetro curvo trasparente. Top in vetro temperato trasparente.
Extendible table with polished aluminium mechanism and base in transparent curved glass. Top in tempered transparent glass.

TEMPLE

design by Studio 28

Temple_Art. 8003B C81 V81A

Tavolo allungabile con bianario in alluminio
brillantato e base in vetro curvo trasparente.
Top in vetro temperato trasparente.

*Extendible table with polished aluminium
mechanism and base in transparent curved glass.
Top in tempered transparent glass.*

Plaza_Art. 7299 K01

Sedia interamente rivestita in vero cuoio bianco.

Chair entirely covered in white genuine thick leather.

TEMPLE

design by Studio 28

TAVOLI FISSI, PIANI IN VETRO
FIXED TABLES, GLASS TOPS

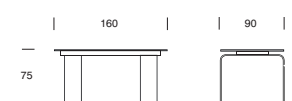

(FP) art. 8003

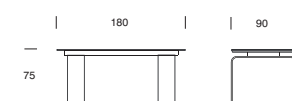

(FA) art. 8003

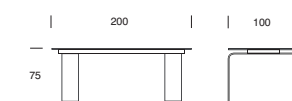

(FG) art. 8003

TAVOLI ALLUNGABILI, PIANI IN VETRO
EXTENDIBLE TABLES, GLASS TOPS

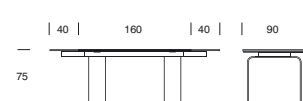

(P) art. 8003

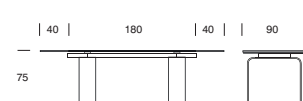

(A) art. 8003

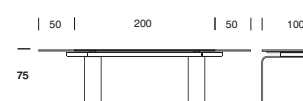

(G) art. 8003

FINITURE BASE
IN VETRO
GLASS BASE FINISHING



C81
TRASPARENTE
TRANSPARENT



C100
EXTRA CHIARO TRASPARENTE
EXTRA CLEAR TRANSPARENT

FINITURE PIANI
IN VETRO
GLASS TOP FINISHING



V81
TRASPARENTE
TRANSPARENT



V100
EXTRA CHIARO TRASPARENTE
EXTRA CLEAR TRANSPARENT

FINITURE BINARIO
PER PIANI FISSI E
ALLUNGABILI
MECHANISM FINISHING
FOR EXTENDIBLE AND
FIXED TOPS



32
ALLUMINIO ANODIZZATO
ANODIZED ALUMINIUM



71
ALLUMINIO BRILLANTATO
POLISHED ALUMINIUM



Temple_Art. 8003B C81 V81A
Tavolo allungabile con binario in alluminio
brillantato e base in vetro curvo trasparente. Top
in vetro temperato trasparente.
Extendible table with polished aluminium
mechanism and base in transparent curved glass.
Top in tempered transparent glass.

CUB

design by Studio Tonin Creatives

TAVOLO CUB ART. 8073

Tavolo allungabile con struttura cromata o laccata bianca e piano in melaminico tinta champagne o carbone chiaro.
Cub è perfetto per chi ha la necessità di ottimizzare gli spazi senza rinunciare allo stile.

Extendible table with chromed or lacquered white structure and top in champagne or light coal melamine.
Cub is perfect for those who need to optimize spaces without sacrificing style.

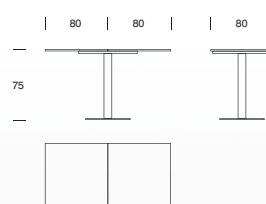

art. 8073

FINITURE BASE BASE FINISHING



01
BIANCO OPACO
MATT WHITE



73
ACCIAIO INOX LUCIDO
POLISHED STAINLESS
STEEL

FINITURE PIANI DI SERIE TOP STANDARD FINISHING



01
BIANCO OPACO
MATT WHITE



L60
EFFETTO LEGNO
TINTA CHAMPAGNE
WOOD EFFECT CHAMPAGNE
COLOUR



L64
EFFETTO LEGNO
TINTA CARBONE CHIARO
WOOD EFFECT LIGHT CARBON
COLOUR



Cub_Art. 8073 01 L60

Tavolo allungabile con struttura in metallo laccato bianco e piano effetto legno tinta champagne.

Extendible table with structure in lacquered white metal and top with champagne wood effect.

Hole_Art. 7207 BT01 01

Sedia impilabile in polipropilene bianca.

Stackable chair in white polypropylene.

PURE

design by Studio Tonin Creatives

TAVOLO PURE ART. T8072 P/A/FP/FA

Tavolo fisso o allungabile da cucina con struttura in metallo laccato e piano in melaminico disponibile in diverse finiture. Design minimal e praticità sono gli elementi salienti di questo articolo.

Fixed or extendible kitchen table with metal lacquered structure and melamine top available in different finishing. A minimal design and practicality are the main features of this article.

TAVOLI FISSI FIXED TABLES



(P) art. 8072F



(A) art. 8072F

TAVOLI ALLUNGABILI EXTENDIBLE TABLES

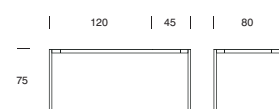

(P) art. 8072

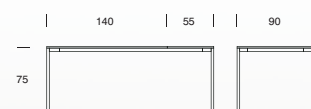

(A) art. 8072

FINITURE BASE BASE FINISHING



01
BIANCO OPACO
MATT WHITE



32
FINITURA ALLUMINIO
OPACO
MATT ALUMINIUM FINISH

FINITURE PIANI DI SERIE TOP STANDARD FINISHING



01
BIANCO OPACO
MATT WHITE



L60
EFFETTO LEGNO TINTA
CHAMPAGNE
WOOD EFFECT CHAMPAGNE
COLOUR



L64
EFFETTO LEGNO TINTA
CARBONE CHIARO
WOOD EFFECT LIGHT CARBON
COLOUR



Pure_Art. 8072 01 L60A
Tavolo allungabile con struttura in metallo laccato bianco e piano effetto legno tinta champagne.
Extendible table with structure in lacquered white metal and top with wood effect champagne finish.

Dalila_Art. 7215 S60
Sedia interamente rivestita in ecopelle tortora.
Chair entirely covered in dove eco-leather.

ELISEO

design by **Studio 28**

TAVOLO ELISEO ART. T8028 TP/T/PE

Tavolo fisso con base in metallo curvato e verniciato, piano in vetro temperato elettro-saldato a raggi UV su piastra d'acciaio per una maggiore qualità e ricercatezza estetica. Disponibile anche nella versione tricolore.

Fixed table with base in curved and lacquered metal, top in tempered glass electro-welded with UV rays onto steel plates for higher quality and refined beauty. Available also in tricolour version.



Eliseo_Art. 8028 31 V100T

Tavolo fisso con base in metallo laccato tricolore e piano in vetro temperato extra chiaro trasparente.
Fixed table with tricoloured lacquered metal base and top in tempered extraclear transparent glass.

Round_Art.7211 S36

Sedia interamente rivestita in ecopelle beige.
Chair entirely covered in beige eco-leather.

Goya_Art. 6107 01

Madia complanare in legno laccato bianco opaco.
Sideboard with sliding doors lacquered in matt white.

ELISEO

design by Studio 28

Un'intreccio armonico, elegante e raffinato che arreda ambienti moderni ma anche ambienti più classici.

A harmonic twine, elegant and refined which furnishes modern but also more classical ambiances.

Eliseo_Art. 8028 51 V81PE
Tavolo fisso con base in metallo laccato fango e piano in vetro temperato trasparente ellittico.

Fixed table with base in lacquered mud metal and top in tempered transparent elliptical glass.

Madeleine_Art. 7276 K51
Sedia interamente rivestita in cuoio fango.
Chair entirely covered in mud thick leather.



ELISEO

design by Studio 28

ELISEO_PIANI VETRO ELISEO_FIXED TABLES_GLAASS TOPS

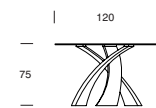

(TP) art. 8061

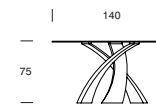

(T) art. 8061

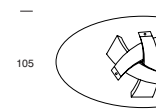

(EL) art. 8061

BIG ELISEO_PIANI VETRO BIG ELISEO_EXTENDIBLE TABLES_GLAASS TOPS

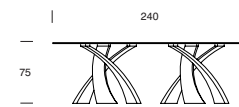

(RZ) art. 8061

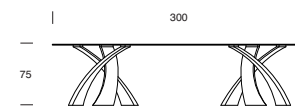

(RK) art. 8061

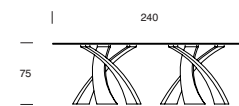
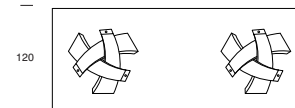

(EZ) art. 8061

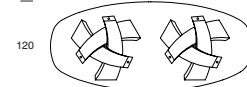

(EZ) art. 8061

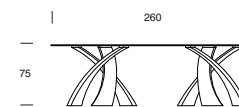

(OK) art. 8061

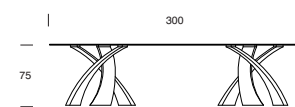

(OX) art. 8061

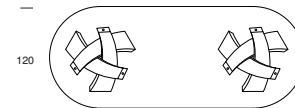

FINITURE BASE BASE FINISHING



01
BIANCO OPACO
MATT WHITE



02
NERO OPACO
MATT BLACK



31
FANGO OPACO
MATT MUD



31
TRICOLORE
TRICOLOURE

FINITURE PIANI IN VETRO GLASS TOP FINISHING



V81
TRASPARENTE
TRANSPARENT



V100
EXTRA CHIARO TRASPARENTE
EXTRA CLEAR TRANSPARENT



Eliseo_Art. 8028 02 V81T
Tavolo fisso con base in metallo laccato nero e piano in vetro temperato trasparente.
Fixed table with base in black lacquered metal and top in tempered transparent glass.

GAYA e BIG GAYA

design by **Angelo Tomaiuolo**

TAVOLO GAYA ART. T8071 TP/T TAVOLO BIG GAYA ART. T8074 RZ/RK/EZ/OK/OX

Tavolo fisso con base realizzata in Tecnoril[®], una pietra acrilica di nuova generazione che garantisce un'elevata resistenza e qualità rigorosamente 100% made in Italy. Forme organiche, come nello stile Tonin Casa, per ritrovare ambienti esclusivi. Disponibile in diverse dimensioni e finiture.

Fixed table with a Tecnoril[®] base, a new generation acrylic stone that guarantees high resistance and a quality 100% Made in Italy. Organic shapes, as per Tonin Casa style, to create an exclusive ambience. Available in different dimensions and finishing.



Gaya_Art. 8071 01 V100T

Tavolo fisso con base in Tecnoril bianca e piano in vetro temperato extrachiaro trasparente.

Fixed table with base in white Tecnoril and top in tempered extraclear transparent glass.

Regina_Art. 7201 TV70

Sedia interamente rivestita in tessuto verbena testa di moro.

Chair entirely covered in dark brown Verbena fabric.



GAYA e BIG GAYA

design by Angelo Tomaiuolo

GAYA
GAYA



(TP) art. 8071



(T) art. 8071



BIG GAYA
BIG GAYA

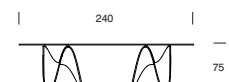

(RZ) art. 8074

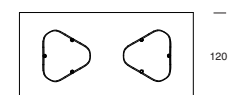

(RZ) art. 8074

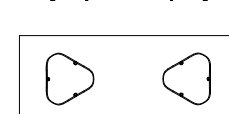

(RK) art. 8074

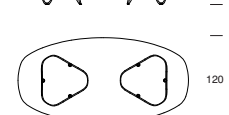

(EZ) art. 8074

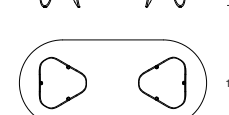
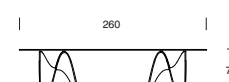

(OK) art. 8074

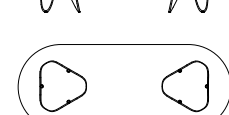
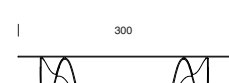

(OX) art. 8074

FINITURE
BASE
BASE
FINISHING



01
BIANCO OPACO
MATT WHITE



05
GRIGIO OPACO
MATT GREY



43
CORDA OPACO
MATT ROPE

FINITURE PIANI
IN VETRO
GLASS TOP
FINISHING



V81
TRASPARENTE
TRANSPARENT



V100
EXTRA CHIARO
TRASPARENTE
EXTRA CLEAR TRANSPARENT



Gaya_Art. 8071 43 V100TP

Tavolo fisso con base in Tecnoril corda opaco e piano in vetro extrachiaro trasparente.

Fixed table with base in matt rope Tecnoril and top in tempered extraclear transparent glass.

Aragona_Art.7209 14 TV51

Sedia finitura noce canaletto rivestita in tessuto Verbena fango.

Chair finished in canaletto walnut and covered in mud Verbena fabric.

IMPERIAL

design by **Studio 28**

TAVOLO IMPERIAL ART. T8010 PEL/EL

*Tavolo fisso con base in agglomerato di marmo e piano in vetro temperato elettro-saldato a raggi UV su piastra d'acciaio.
Imperial nella sua semplicità arricchisce di valore la sala da pranzo. Disponibile in diverse dimensioni e finiture.*

*Fixed table with base in marble agglomerate and top in tempered glass electro-welded with UV rays onto steel plates.
Imperial in its simplicity enriches with added value your living room. Available in various dimensions and finishing.*



Imperial_Art. 8010 501 V101EL
Tavolo fisso con base in agglomerato di marmo laccato bianco e piano ellittico in vetro temperato extra chiaro bianco.
Fixed table with base in lacquered white marble agglomerate and elliptical top in tempered extraclear white glass.

Vivienne_Art. 7258 S02
Sedia rivestita in ecopelle nera.
Chair covered in black eco-leather.

Paris_Art. 8373DV 01 V81
Vetrina 4x3 ante traforate in legno laccato bianco opaco.
Showcase 4x3 with fretted wooden doors lacquered matt white.



IMPERIAL

design by Studio 28

Imperial_Art. 8010 502 V81EL

Tavolo fisso con base in agglomerato di marmo laccato nero e piano ellittico in vetro temperato trasparente.

Fixed table with base in lacquered black marble agglomerate and elliptical top in tempered transparent glass.

Charonne_Art. 7265 PN5

Sedia rivestita in nabuk panna.

Chair covered in cream nabuk.

Asia_Art. 6120 14 V2

Madia ellittica in noce canaletto con ante e fianchi in vetro curvo nero.

Elliptical sideboard in canaletto walnut with doors and sides in black curved glass.

IMPERIAL

design by Studio 28

TAVOLI FISSI_PIANI IN VETRO FIXED TABLES_GLASS TOPS

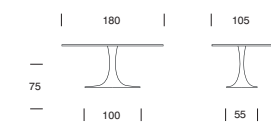



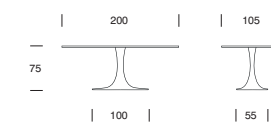





(PEL) art. 8010



(EL) art. 8010



FINITURE BASE BASE FINISHING			
	501 BIANCO LUCIDO GLOSSY WHITE	502 NERO LUCIDO GLOSSY BLACK	560 CHAMPAGNE LUCIDO GLOSSY CHAMPAGNE
	<hr/>		
FINITURE PIANI IN VETRO DI SERIE GLASS TOP STANDARD FINISHING			
	V2 NERO BLACK	V81 TRASPARENTE TRANSPARENT	V100 EXTRA CHIARO TRASPARENTE EXTRA CLEAR TRANSPARENT
	<hr/>		
FINITURE PIANI IN VETRO SU ORDINAZIONE TOP FINISHING IN CUSTOM GLASS			
	V101 EXTRA CHIARO BIANCO EXTRA CLEAR WHITE	<hr/>	
FINITURE PIANI IN VETRO SU ORDINAZIONE TOP FINISHING IN CUSTOM GLASS			
	V160 EXTRA CHIARO CHAMPAGNE EXTRA CLEAR CHAMPAGNE		



Imperial_Art. 8010 502 V81EL
Tavolo fisso con base in agglomerato di marmo laccato nero e piano ellittico in vetro temperato trasparente.
Fixed table with base in lacquered black marble agglomerate and elliptical top in tempered transparent glass.

Charonne_Art. 7265 PN5
Sedia rivestita in nabuk panna.
Chair covered in cream nabuk.

Asia_Art. 6120 14 V2
Madia ellittica in noce canaletto con ante e fianchi in vetro curvo nero.
Elliptical sideboard in canaletto walnut with doors and sides in black curved glass.

BEXLEY

design by **Nicola Tonin**

TAVOLO BEXLEY ART. T8029 QS/RS

*Tavolo fisso con basi in agglomerato di marmo e piano in vetro temperato sagomato.
Forme di ispirazione classica che rendono questo tavolo estremamente originale.
Disponibile in diverse dimensioni e finiture.*

*Fixed table with base in marble agglomerate and top in profiled tempered glass.
The shapes of classical inspiration makes this table extremely original.
Available in different dimensions and finishing.*



Bexley_Art. 8029 501 V100QS

Tavolo fisso con gambe in agglomerato di marmo laccato bianco e piano sagomato in vetro temperato extra chiaro trasparente.

Fixed table with legs in lacquered white marble agglomerate and profiled top in tempered profiled extraclear transparent glass.

Sorbona_Art. 7295 S01

Sedia interamente rivestita in ecopelle bianca.

Chair entirely covered in white eco-leather.



BEXLEY

design by Nicola Tonin

Bexley_Art. 8029 502 V2RS
Tavolo fisso con gambe in agglomerato di marmo laccato nero e piano sagomato in vetro temperato nero.
Fixed table with legs in lacquered black marble agglomerate and profiled top in black tempered glass.

Vivienne_Art. 7258 PF29
Sedia rivestita in pelle fiore grigio gabbiano.
Chair covered in gull grey grain leather.

Paris_Art. 8373DV 01 V81
Vetrina 4x3 con luci LED e ante traforate in legno laccato bianco opaco.
Showcase 4x3 with LED lights and fretted doors in matt white lacquered wood.

BEXLEY

design by Nicola Tonin

TAVOLI FISSI_PIANI IN VETRO FIXED TABLES_GLASS TOPS

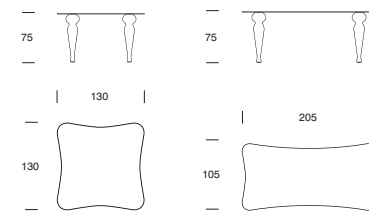

(QS) art. 8029

(RS) art. 8029

FINITURE BASE BASE FINISHING



501
BIANCO LUCIDO
GLOSSY WHITE



502
NERO LUCIDO
GLOSSY BLACK



550
CHAMPAGNE LUCIDO
GLOSSY CHAMPAGNE

FINITURE PIANI IN VETRO DI SERIE GLASS TOPS STANDARD FINISHING



V2
NERO
BLACK



V81
TRASPARENTE
TRANSPARENT



V100
EXTRA CHIARO TRASPARENTE
EXTRA CLEAR TRANSPARENT



V101
EXTRA CHIARO BIANCO
EXTRA CLEAR WHITE

FINITURE PIANI IN VETRO SU ORDINAZIONE TOP FINISHING CUSTOM GLASS



V160
EXTRA CHIARO CHAMPAGNE
EXTRA CLEAR CHAMPAGNE



Bexley_Art. 8029 502 V2RS
Tavolo fisso con gambe in agglomerato di marmo laccato nero e piano sagomato in vetro temperato nero.

Fixed table with legs in lacquered black marble agglomerate and profiled top in black tempered glass.

Vivienne_Art. 7258 PF29
Sedia rivestita in pelle fiore grigio gabbiano.

Chair covered in gull grey grain leather.

ARPA

design by **Angelo Tomaiuolo**

CONSOLLE ARPA ART. T6470

Intrecci di legno curvato tinto bianco, noce canaletto o rovere scuro, sostengono un piano in vetro temperato o in prezioso marmo disponibile in diverse finiture.

Il massimo dell'eleganza e del design per un complemento che davvero fa la differenza!

Curved wooden braids in white, canaletto walnut or dark oak, support tempered glass or marble top available in different finishing.

The utmost elegance for an occasional piece that really makes the difference!



Arpa_Art. 6470 14 M129
Consolle con base in legno curvato nocecanaletto e piano in marmo grigio lucido.

Console with base in curved canaletto walnut and top in glossy grey marble.

Stone_Art. 7529 P
Specchiera sagomata.
Profiled mirror.

ARPA

design by **Angelo Tomaiuolo**

L'eleganza del marmo accostata al legno rendono Arpa una consolle unica da abbinare a tanti altri articoli della collezione Arpa, come il tavolo o la libreria.

The elegance of marble combined with wood makes Arpa a really unique console, to match with all other articles from the Arpa collection, such as the table or the shelving units.

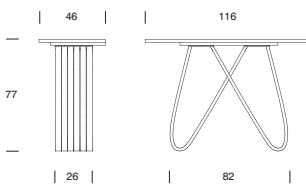

art. 6470

FINITURE
BASE
STRUCTURE
FINISHING



01
BIANCO
WHITE



14
NOCE CANALETTO
CANALETTO WALNUT



16
ROVERE SCURO
TERMOTRATTATO
DARK OAK HEAT-TREATED

FINITURE PIANI
IN MARMO
MARBLE TOP
FINISHING



M101
BIANCO CARRARA LUCIDO
GLOSSY WHITE CARRARA



M102
NERO MARQUINA LUCIDO
GLOSSY BLACK MARQUINA



M129
MARMO GRIGIO LUCIDO
GLOSSY GREY MARBLE

FINITURE PIANI
IN VETRO
GLASS TOP
FINISHING



V2
NERO
BLACK



V101
EXTRA CHIARO BIANCO
EXTRA CLEAR WHITE

Arpa_Art. 6470 01 V101

Consolle con base in legno curvato
lacrato bianco e piano in vetro
extra chiaro bianco.

Console with base in lacquered white
curved wood and white extra clear
tempered glass top.

Toshima_Art. 5032 V101

Specchio con cornice in vetro
extra chiaro verniciato bianco.

Mirror with white extra clear tempered
glass frame.

ALTAMURA

design by Studio Tonin Creatives

CONSOLLE ALTAMURA ART. T6460

*Consolle in vetro curvo con ripiano in legno.
Semplice ma di effetto arreda i piccoli spazi di casa rendendoli funzionali.*

*Console in curved glass with wooden top.
Simple yet effective, it decorates a small ambience making it functional.*

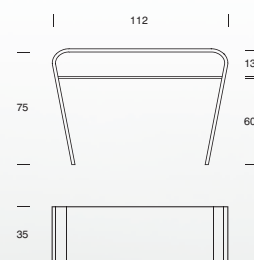

art. 6460

FINITURE STRUTTURA
VETRO
GLASS FINISHING
STRUCTURE



V81
TRASPARENTE
TRANSPARENT GLASS



V100
EXTRACHIARO
TRASPARENTE
EXTRA CLEAR GLASS

FINITURE RIPIANI IN
VETRO
GLASS SHELF
FINISHING

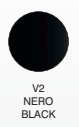

V2
NERO
BLACK



V101
EXTRA CHIARO BIANCO
EXTRA CLEAR WHITE

FINITURE RIPIANO
LEGNO
WOOD SHELF
FINISHING

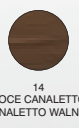

14
NOCE CANALETTO
CANALETTO WALNUT

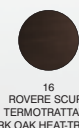

16
ROVERE SCURO
TERMOTRATTATO
DARK OAK HEAT-TREATED



Altamura_Art.6460 V100 14
Consolle in vetro curvato extra
chiaro trasparente e ripiano in
legno noce canaletto.
Console in curved extraclear
transparent glass and shelf in
canaletto walnut.

AMELIA

design by **Studio Tonin Creatives**

CONSOLLE AMELIA ART. T6471 P/A/G/D

*Consolle che grazie ad un pacchetto di allunghe diventa comodo tavolo.
Grande praticità pensata per chi possiede ambienti ridotti e non vuole rinunciare al design moderno.
Disponibile in diverse finiture.*

*Amelia is a console that, using its system of extensions, becomes a comfortable dining table.
Great practicality, created for small environments but without giving up on modern design.
Available in different finishing.*



Amelia_Art. 6471 L201G
Consolle/tavolo allungabile
laccata bianca effetto
frassino.

*Extendible console/table in
lacquered white ash effect.*

Dalla_Art. 7215 S60
Sedia interamente rivestita in
ecopelle tortora.
*Chair entirely covered in
dove eco-leather.*

AMELIA

design **Studio Tonin Creatives**

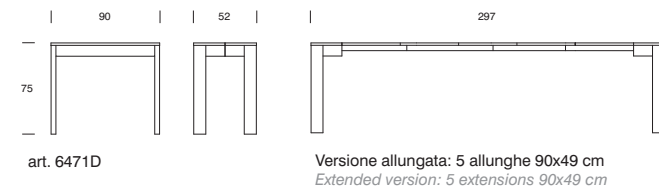
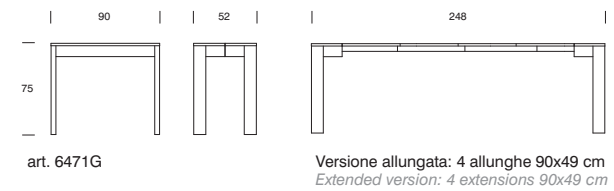
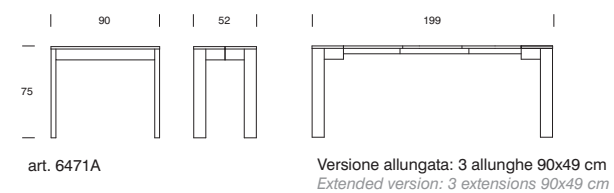
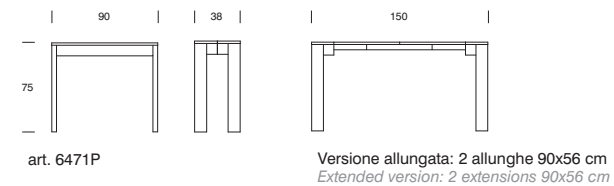

FINITURE BASE
STRUCTURE FINISHING



L201
BIANCO MELAMINICO EFFETTO
FRASSINO
MELAMINE WHITE ASH EFFECT



L264
GRIGIO MELAMINICO EFFETTO
FRASSINO
MELAMINE GREY ASH EFFECT

Amelia_Art. 6471 L264D
Consolle/tavolo allungabile
laccata grigio effetto frassino.
Console / extendible table,
lacquered grey ash effect.



Sedie, sgabelli e pouff

*chairs, bar stools
and poufs*

*Mivida
Aragona
Charm
Vivienne
Charonne
Sorbona
Colette
Giudecca
Belem
Dalila
Stella
Madeleine
Deira
Ginza
Carilla
Plaza
Vittoria
Aria Easy
Oslo
Real
Milano
New York
Asola
Truly*



MIVIDA

design by **Angelo Tomaiuolo**

POLTRONCINA MIVIDA ART. T7213 SEDIA MIVIDA ART. T7212

*Seduta realizzata in poliuretano schiumato a freddo, con struttura in legno e rivestimento in pelle, pelle fiore, pelle nabuk o ecopelle.
Il massimo della qualità e dell'artigianalità si racchiude in questa opera manifatturiera
dove solo esperti sarti sanno esaltare le forme di Mivida.*

*Chair made in cold foamed polyurethane, with wooden structure and covered in leather, full grain leather, nabuk leather or eco-leather.
Top quality and craftsmanship combine in this manufactured masterpiece,
as only skilled tailors can enhance the shapes of Mivida.*



Mivida_Art.7212 14 S70
Sedia finitura noce canaletto e
rivestita ecopelle testa di moro.
Chair finished in walnut and
covered in dark brown eco-leather.

Mivida_Art.7213 14 PF68
Poltroncina finitura noce canaletto
e rivestita pelle fiore ambrata.
Armchair finished in walnut and
covered in yellow grain leather.

Mivida_Art.7212 14 S28
Sedia finitura noce canaletto e
rivestita ecopelle bianco avana.
Chair finished in walnut and
covered in havana white eco-
leather.

MIVIDA

design by Angelo Tomaiuolo



Mivida_Art. 7212 17 PN5
Sedia laccata rovere naturale
e rivestita in pelle nabuk panna.
Natural oak lacquered chair
covered in cream nabuk leather.



Mivida_Art.7212 14 PF47
Sedia finitura noce canaletto e
rivestita in pelle fiore cipria.
Chair finished in canaletto
walnut and covered in powder
grain leather.

MIVIDA

design by **Angelo Tomaiuolo**



Mivida_Art. 7212 17 PN5
Poltroncina laccata rovere naturale e rivestita in pelle nabuk panna.
Natural oak lacquered armchair covered in cream nabuk leather.

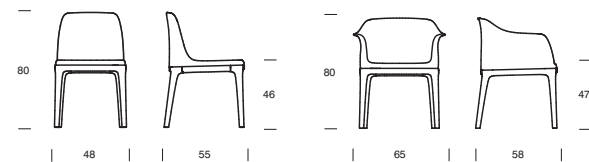

art. 7212

art. 7213

RIVESTIMENTI COVERING

PER IL CAMPIONARIO
COMPLETO VEDI LE
PAGINE FINALI
FOR THE COMPLETE
SAMPLE SEE THE FINAL
PAGES

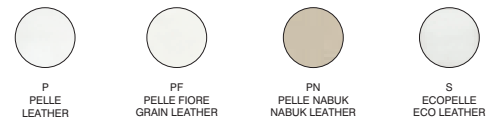

P PELLE LEATHER
PF PELLE FIORE GRAIN LEATHER
PN PELLE NABUK NABUK LEATHER
S ECOPELLE ECO LEATHER

STRUTTURA STRUCTURE

PER CORDONATURA VEDI
LISTINO
FOR PIPING SEE PRICE LIST



14 FRASSINO TINTO NOCE CANALETTO
ASH IN CANALETTO WALNUT
THERMOTREATED FINISHING
16 FRASSINO TINTO ROVERE
SCURO TERMOTRATTATO
ASH IN DARK OAK
THERMOTREATED FINISHING
17 FRASSINO TINTO ROVERE
NATURALE
ASH IN NATURAL OAK
THERMOTREATED FINISHING



Mivida_Art.7213 14 P52
Poltroncina finitura noce canaletto e rivestita pelle lavanda.
Armchair finished in canaletto walnut and covered in lavender leather.

ARAGONA

design by **Studio Tonin Creatives**

SEDIA ARAGONA ART. T7209

*Sedia con struttura in legno frassino tinto noce, rovere scuro e rovere naturale.
Rivestimento in pelle, pelle fiore, pelle nabuk, ecopelle o tessuto.
Il massimo della versatilità e dell'eleganza per adattare Aragona in qualsiasi ambiente.*

*Chair with wood structure, lacquered walnut dark oak or natural oak.
Covered in leather; full grain leather, nabuk leather, eco-leather or fabric.
Top versatility and elegance enable Aragona to adapt to any ambience.*



Aragona_Art. 7209 16 PN51
Sedia finitura rovere scuro
termotrattato rivestita in nabuk
fango.
*Dark oak thermo treated finish chair
covered in mud nabuk leather.*

ARAGONA

design by Studio Tonin Creatives

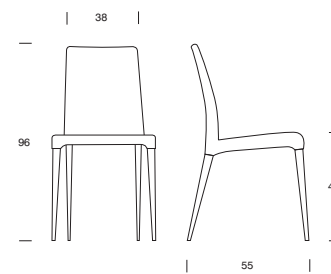

art. 7209

RIVESTIMENTI COVERING

PER IL CAMPIONARIO
COMPLETO VEDI LE
PAGINE FINALI
FOR THE COMPLETE
SAMPLE SEE THE FINAL
PAGES



P
PELLE
LEATHER



PF
PELLE FIORE
GRAIN LEATHER



PN
PELLE NABUK
NABUK LEATHER



S
ECOPELLE
ECO LEATHER



TV
TESSUTO VERBENA
VERBENA FABRIC



TN
TESSUTO NINFEA
NINFEA FABRIC

STRUTTURA STRUCTURE

PER IL CAMPIONARIO
COMPLETO VEDI LE
PAGINE FINALI
FOR THE COMPLETE
SAMPLE SEE THE FINAL
PAGES



14
FRASSINO TINTO NOCE CANALETTO
ASH IN CANALETTO WALNUT
THERMOTREATED FINISHING



16
FRASSINO TINTO ROVERE
SCURO THERMOTRATTATO
ASH IN DARK OAK
THERMOTREATED FINISHING



17
FRASSINO TINTO ROVERE
NATURALE
ASH IN NATURAL OAK
THERMOTREATED FINISHING

Aragona_Art. 7209 17 TV01

Sedia finitura rovere naturale
rivestita in tessuto Verbena
bianco.

Natural oak finish chair
covered in white Verbena
fabric.

CHARM

design by **Studio Tonin Creatives**

SEDIA CHARM ART. T7216

*Seduta imbottita in gomma indeformabile ad alta densità per avere comfort ed eleganza.
Cuciture artigianali e vasta gamma di finiture, ecopelle, pelle, pelle nabuk
e pelle fiore per incontrare i gusti più esigenti.*

*This chair is padded with non-deformable high density rubber to obtain comfort and elegance.
Artisan stitching and wide range of finishing, eco-leather, leather, nabuk leather
or full grain leather to satisfy even the most demanding taste.*



Charm_Art. 7216 S70
Sedia rivestita in ecopelle testa di moro.
Chair covered in dark brown eco-leather.

CHARM

design by **Studio Tonin Creatives**

*Solo il marchio Tonin Casa
100% Made in Italy garantisce
la vera autenticità nonché
qualità dei nostri prodotti.
Diffidate dalle imitazioni!*

*Only the marking Tonin
Casa 100% Made in Italy
guarantees true authenticity
and quality of our products .
Don't trust imitations!*

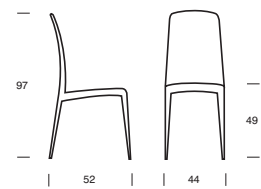

art. 7216

RIVESTIMENTI COVERING

PER IL CAMPIONARIO
COMPLETO VEDI LE
PAGINE FINALI
FOR THE COMPLETE
SAMPLE SEE THE FINAL
PAGES



P
PELLE
LEATHER



PF
PELLE FIORE
GRAIN LEATHER



PN
PELLE NABUK
NABUK LEATHER



S
ECOPELLE
ECO LEATHER



Charm_Art. 7216 S51
Sedia rivestita in ecopelle fango.
Chair covered in mud eco-leather.

VIVIENNE

design by Studio 28

SEDIA VIVIENNE ART. T7258

Seduta realizzata in poliuretano schiumato a freddo, rivestita in pelle, pelle fiore, pelle nabuk, ecopelle o tessuto con struttura in metallo cromato. Design morbido e contemporaneo pensato per le personalità più esigenti. Disponibile anche nella versione ignifuga e sfoderabile.

Chair made with cold foamed polyurethane, entirely covered in leather, full grain leather, nabuk leather, eco leather or fabric with a chromed metal structure. A soft contemporary design created for the most demanding personalities. Available also with removable cover and in fire retardant versions.



Vivienne_Art. 7258 PF6
Sedia rivestita in pelle fiore rosa.
Chair covered in pink grain leather.

VIVIENNE

design by Studio 28

Personalizza la tua sedia scegliendo tra le diverse tipologie di pelle e tra l'infinita gamma di colori che Tonin Casa ti offre.

Customize your chair by choosing among the different kinds of leather and the never ending variety of colours that Tonin Casa offers.



Vivienne_Art. 7258 PF29
Sedia rivestita in pelle fiore grigio gabbiano.
Chair covered in grey gull grain leather.



Vivienne_Art. 7258 PF65
Sedia rivestita in pelle fiore rosso mattone.
Chair covered in brick red grain leather.

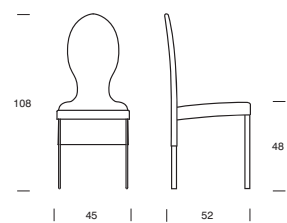

art. 7258

RIVESTIMENTI COVERING

PER IL CAMPIONARIO
COMPLETO VEDI LE
PAGINE FINALI
FOR THE COMPLETE
SAMPLE SEE THE FINAL
PAGES



P
PELLE
LEATHER



PF
PELLE FIORE
GRAIN LEATHER



PN
PELLE NABUK
NABUK LEATHER



S
ECOPELLE
ECO LEATHER



TV
TESSUTO VERBENA
VERBENA FABRIC



TN
TESSUTO NINFEA
NINFEA FABRIC

CHARONNE

design by Studio 28

SEDIA CHARONNE ART. T7265

Seduta realizzata in poliuretano schiumato a freddo, rivestita in pelle, pelle fiore, pelle nabuk, ecopelle o tessuto con struttura in metallo cromato. Uno stile moderno ed intramontabile pensato per le personalità più esigenti. Disponibile anche nella versione ignifuga e sfoderabile.

Chair made in cold foamed polyurethane covered in leather, full grain leather, nabuk leather, eco leather or fabric with chromed metal structure. A modern and everlasting style to satisfy even the most demanding taste. Available also with removable cover and in fire retardant versions.



Charonne Art. 7265 PN5
Sedia rivestita in pelle nabuk panna.
Chair covered in cream nabuk leather.

CHARONNE

design by Studio 28

Solo schiumati ergonomici di primo ordine e una attenta selezione di pelli nei diversi colori rendono unici ed inimitabili i prodotti Tonin Casa.

Only first class ergonomic foam and a careful selection of the different leather colours make Tonin Casa products unique and inimitable.



Charonne_Art.7265 S44
Sedia rivestita in ecopelle blu notte.
Night Blue eco-leather covered chair.

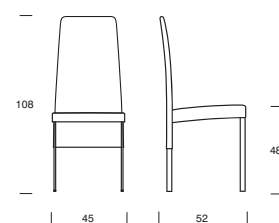

art. 7265

RIVESTIMENTI COVERING

PER IL CAMPIONARIO
COMPLETO VEDI LE
PAGINE FINALI
FOR THE COMPLETE
SAMPLE SEE THE FINAL
PAGES



P
PELLE
LEATHER



PF
PELLE FIORE
GRAIN LEATHER



PN
PELLE NABUK
NABUK LEATHER



S
ECOPELLE
ECO LEATHER



TV
TESSUTO VERBENA
VERBENA FABRIC



TN
TESSUTO NINFEA
NINFEA FABRIC



Charonne_Art. 7265 S02
Sedia rivestita in ecopelle nera.
Chair covered in black eco-leather.

SORBONA

design by Studio 28

SEDIA SORBONA ART. T7295

Seduta realizzata in poliuretano schiumato a freddo, completamente rivestita in pelle, pelle fiore, pelle nabuk o ecopelle. Sorbona è pensata per chi vuole la massima eleganza.

Chair made out of cold foamed polyurethane, entirely covered in leather, full grain leather, nabuk leather or eco leather. Sorbona has been created for those who wish to be surrounded by maximum elegance.

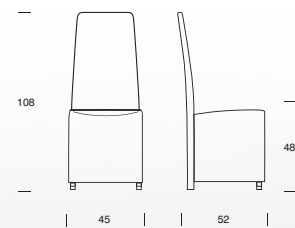

art. 7295

RIVESTIMENTI COVERING

PER IL CAMPIONARIO
COMPLETO VEDI LE
PAGINE FINALI
FOR THE COMPLETE
SAMPLE SEE THE FINAL
PAGES



P
PELLE
LEATHER



PF
PELLE FIORE
GRAIN LEATHER



PN
PELLE NABUK
NABUK LEATHER



S
ECOPELLE
ECO LEATHER



Sorbona_Art.7295 PF33
Sedia interamente rivestita
in pelle fiore cobalto.
Chair entirely covered in
cobalt grain leather.

COLETTE

design by Studio 28

SEDIA COLETTE ART. T7281

Seduta imbottita in gomma indeformabile ad alta densità interamente rivestita in pelle, pelle fiore, pelle nabuk o ecopelle. Lavorazione "welded" nello schienale per un effetto capitonné elegante e originale.

This chair is padded with non-deformable high density rubber entirely covered in leather, full grain leather, nabuk leather or eco leather. Welded processing for the backrest, to create an elegant and original capitonné effect.

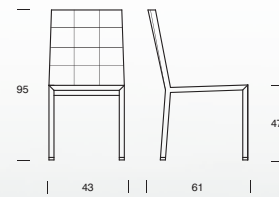

art. 7281

RIVESTIMENTI COVERING

PER IL CAMPIONARIO
COMPLETO VEDI LE
PAGINE FINALI
FOR THE COMPLETE
SAMPLE SEE THE FINAL
PAGES



P
PELLE
LEATHER



PF
PELLE FIORE
GRAIN LEATHER



PN
PELLE NABUK
NABUK LEATHER



S
ECOPELLE
ECO LEATHER



Colette_Art.7281 S36
Sedia con lavorazione
capitonné rivestita in
ecopelle beige.
Chair with capitonné back
covered in beige eco-leather.

GIUDECCA

design by Studio 28

SEDIA GIUDECCA ART. T7267 - T7267B

*Seduta con struttura in metallo interamente rivestita in pelle, pelle fiore, pelle nabuk o ecopelle.
Linee pulite e grande comodità sono le caratteristiche principali di questa sedia.*

*Metal structure seating entirely covered in leather, full grain leather, nabuk leather or eco-leather.
Clean lines and great comfort are the main features of this chair.*

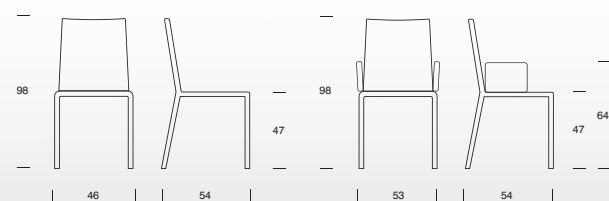

art. 7267

art. 7267B

RIVESTIMENTI COVERING

PER IL CAMPIONARIO
COMPLETO VEDI LE
PAGINE FINALI
FOR THE COMPLETE
SAMPLE SEE THE FINAL
PAGES



P
PELLE
LEATHER



PF
PELLE FIORE
GRAIN LEATHER



PN
PELLE NABUK
NABUK LEATHER



S
ECOPELLE
ECO LEATHER



Giudecca_Art. 7267 P29
Sedia interamente
rivestita in pelle grigio
gabbiano.
Grey gull leather covered
chair.

BELEM

design by Studio 28

SEDIA BELEM ART. T7272

*Sedia con struttura in metallo interamente rivestita in pelle, pelle fiore, pelle nabuk o ecopelle.
Un design semplice e senza tempo da personalizzare grazie alle tante colorazioni disponibili tra i diversi rivestimenti.*

*Chair with a metal structure entirely covered in leather, full grain leather, nabuk leather or eco-leather.
A simple and timeless design that can be personalized using the many tones of colour available in covering.*

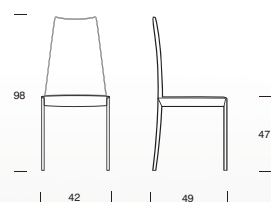

art. 7272

RIVESTIMENTI
COVERING

PER IL CAMPIONARIO
COMPLETO VEDI LE
PAGINE FINALI
FOR THE COMPLETE
SAMPLE SEE THE FINAL
PAGES



P
PELLE
LEATHER



PF
PELLE FIORE
GRAIN LEATHER



PN
PELLE NABUK
NABUK LEATHER



S
ECOPELLE
ECO LEATHER



Belem_Art. 7272 S01
Sedia rivestita in ecopelle bianca.
Chair covered in white eco-leather.

DALILA

design by Studio Tonin Creatives

SEDIA DALILA ART. T7215

*Seduta completamente rivestita in ecopelle, pelle, pelle nabuk o pelle fiore.
Un design semplice e funzionale che si adatta a tutti gli ambienti domestici.*

*Chair completely covered in eco leather, leather, nabuk leather or full grain leather.
A design which is simple and functional, easy to adapt to all rooms in the household.*

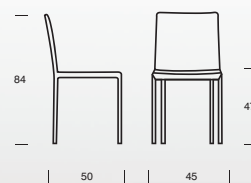

art. 7215

RIVESTIMENTI

COVERING

PER IL CAMPIONARIO
COMPLETO VEDI LE
PAGINE FINALI
FOR THE COMPLETE
SAMPLE SEE THE FINAL
PAGES



P
PELLE
LEATHER



PF
PELLE FIORE
GRAIN LEATHER



PN
PELLE NABUK
NABUK LEATHER



S
ECOPELLE
ECO LEATHER



Dalila_Art. 7215 S01
Sedia interamente rivestita
in ecopelle bianca.
Chair entirely covered in
white eco-leather.

STELLA

design by Studio 28

SEDIA STELLA ART. T7263

Sedia con struttura in metallo cromato e rivestita in pelle, pelle fiore, pelle nabuk, ecopelle o tessuto.
Stella è impilabile per ovviare alle problematiche di spazio e sfoderabile.

Chair with chromed metal structure covered in leather, full grain leather, nabuk leather, eco-leather or fabric.
Stella is stackable, to save space and has a removable cover.

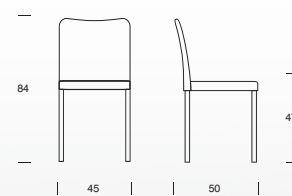

art. 7263

RIVESTIMENTI COVERING

PER IL CAMPIONARIO
COMPLETO VEDI LE
PAGINE FINALI
FOR THE COMPLETE
SAMPLE SEE THE FINAL
PAGES



P

PELLE
LEATHER



PF

PELLE FIORE
GRAIN LEATHER



PN

PELLE NABUK
NABUK LEATHER



S

ECOPELLE
ECO LEATHER



TV

TESSUTO VERBENA
VERBENA FABRIC



TN

TESSUTO NINFEA
NINFEA FABRIC



Stella_Art. 7263 S60
Sedia sfoderabile e impilabile
rivestita in ecopelle tortora.
Chair with removable lining,
stackable and covered in dove
eco-leather.

MADELEINE

design by Studio 28

SEDIA MADELEINE ART. T7276 - T7268 - T7268B

*Seduta con struttura in metallo interamente rivestita in vero cuoio.
Disponibile anche nella versione con braccioli o con seduta più larga.
Madeleine è la sedia perfetta; la sua semplicità e il suo grande comfort la rendono unica e senza tempo.*

*Chair with a metal structure entirely covered in real thick leather.
Available also in the version with armrest or with a larger seat.
Madeleine is the perfect chair; its simplicity and comfort are those of a chair which is unique and timeless.*



Madeleine_Art. 7276 K01
Sedia interamente rivestita in vero cuoio bianco.
Chair covered in white thick leather.

MADELEINE

design by Studio 28

*Cuciture attente
in ogni particolare
e cuoio di prima
qualità stanno alla
base della sedia
Madeleine.*

*Stitching that takes
care of details and
first quality hide
are the secret of our
Madeleine chair.*

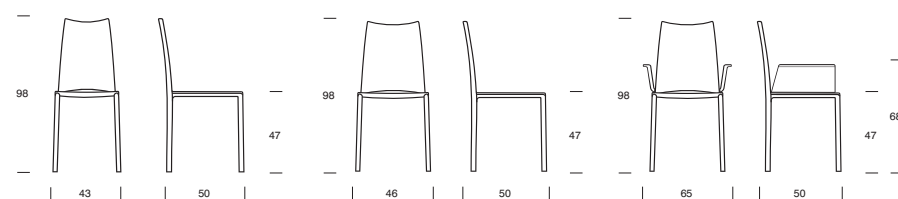

art. 7276

art. 7268

art. 7268B

RIVESTIMENTI COVERING

PER IL CAMPIONARIO
COMPLETO VEDI LE
PAGINE FINALI
FOR THE COMPLETE
SAMPLE SEE THE FINAL
PAGES

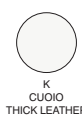

K
CUOIO
THICK LEATHER



K912
NATURALE NUVOLATO
NATURALLY CLOUDED



Madeleine_Art.7268B K91
Sedia interamente rivestita in
cuoio testa di moro, con braccioli.
Armchair entirely covered in
dark brown thick leather.

DEIRA

design by Studio 28

SEDIA DEIRA ART. T7278

*Sedia con struttura in metallo cromato rivestita in cuoio.
Disegno originale e materia prima di eccellente qualità fanno di Deira un prodotto inimitabile.*

*Chair with chromed metal covered in leather.
Its original design and the excellent quality of raw material make Deira an inimitable product.*

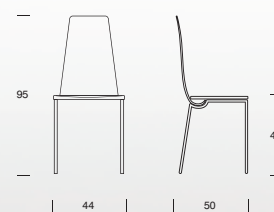

art. 7278

RIVESTIMENTI
COVERING

PER IL CAMPIONARIO
COMPLETO VEDI LE
PAGINE FINALI
FOR THE COMPLETE
SAMPLE SEE THE FINAL
PAGES

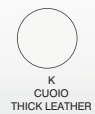

K
CUOIO
THICK LEATHER



KN32
NATURALE NUVOLATO
NATURALLY CLOUDED



Deira_Art. 7278 K01
Sedia rivestita in cuoio bianco.
Chair covered in white thick leather.

GINZA

design by Studio 28

SEDIA GINZA ART. T7275

*Sedia con struttura a slitta in metallo cromato e rivestita cuoio.
Ginza è stata pensata sia per le sale da pranzo sia per studi più esigenti.*

*Chair with chromed metal sled pedestal and covered in thick leather.
Ginza has been designed both for congress rooms and for dining rooms.*

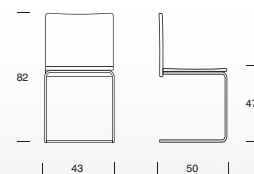

art. 7275

RIVESTIMENTI
COVERING

PER IL CAMPIONARIO
COMPLETO VEDI LE
PAGINE FINALI
FOR THE COMPLETE
SAMPLE SEE THE FINAL
PAGES



K
CUOIO
THICK LEATHER



K132
NATURALE NUVOLATO
NATURALLY CLOUDED



Ginza_Art. 7275 K51
Sedia rivestita in cuoio fango.
Chair covered in mud thick
leather.

CARILLA

design by **Studio Archirivolto**

SEDIA CARILLA ART. T7214

*Linee pulite e massima eleganza per la seduta in vero cuoio Carilla.
Struttura in metallo cromato e rivestimento in cuoio disponibile in diverse finiture per creare
gli abbinamenti più "stilosi" per la propria abitazione.*

*Clean lines and utmost elegance for this real leather chair.
Structure in chromed metal and leather covering available in different finishing to create
the most stylish matching in your home.*



art. 7214

RIVESTIMENTI
COVERING

PER IL CAMPIONARIO
COMPLETO VEDI LE
PAGINE FINALI
FOR THE COMPLETE
SAMPLE SEE THE FINAL
PAGES



K
CUOIO
THICK LEATHER



KN32
NATURALE NUVOLATO
NATURALLY CLOUDED



Carilla_Art. 7214 K01
Sedia rivestita in cuoio bianco.
Chair covered in white thick leather.

PLAZA

design by **Studio Tonin Casa Creatives**

SEDIA PLAZA ART. T7299

*Seduta con struttura in metallo interamente rivestita in vero cuoio.
Design semplice e di qualità per il massimo del made in Italy.*

*Chair with chromed metal structure entirely covered in real thick leather.
A simple quality design for a typical Made in Italy product*

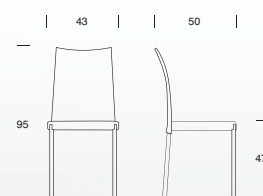

art. 7299

RIVESTIMENTI
COVERING

PER IL CAMPIONARIO
COMPLETO VEDI LE
PAGINE FINALI
FOR THE COMPLETE
SAMPLE SEE THE FINAL
PAGES

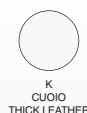

K
CUOIO
THICK LEATHER



K132
NATURALE NUVOLATO
NATURALLY CLOUDED



Plaza_Art. 7299 K01
Sedia interamente rivestita
in vero cuoio bianco.
Chair entirely covered in
white thick leather.

VITTORIA

design by Studio 28

SEDIA VITTORIA ART. T7273

*Sedia con struttura in metallo cromato rivestita in vero cuoio.
Vittoria rappresenta il vero Made in Italy sia nella qualità delle materie prime usate sia nella qualità delle lavorazioni.*

*Chair with chromed metal structure covered in real thick leather.
Vittoria stands for the true Made in Italy quality, both in the raw materials involved as in the level of craftsmanship.*

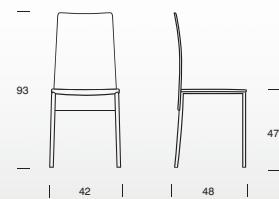

art. 7273

RIVESTIMENTI COVERING

PER IL CAMPIONARIO
COMPLETO VEDI LE
PAGINE FINALI
FOR THE COMPLETE
SAMPLE SEE THE FINAL
PAGES



K
CUOIO
THICK LEATHER



K552
NATURALE NUBOLATO
NATURALLY CLOUDED



Vittoria_Art. 7273 K51
Sedia rivestita in vero
cuoio fango.
Chair covered in mud
thick leather.

ARIA EASY

design by Studio 28

SEDIA ARIA EASY ART. T7204

*Sedia impilabile stampata in policarbonato con struttura in metallo cromato o verniciato.
Aria è semplicemente espressione di resistenza, leggerezza e semplicità.*

*Stackable chair pressed in polycarbonate with a chromed metal structure or lacquered.
Aria is the pure expression of resistance, lightness and simplicity.*

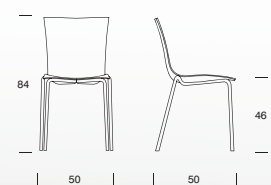

art. 7204

SEDUTA SEAT

PER IL CAMPIONARIO
COMPLETO VEDI LE
PAGINE FINALI
FOR THE COMPLETE
SAMPLE SEE THE FINAL
PAGES



BT1
TRASPARENTE
TRANSPARENT



BT5
FUMÈ TRASPARENTE
TRANSPARENT FUME



BT01
BIANCO LUCIDO
GLOSSY WHITE



BT02
NERO LUCIDO
GLOSSY BLACK

STRUTTURA STRUCTURE

PER IL CAMPIONARIO
COMPLETO VEDI LE
PAGINE FINALI
FOR THE COMPLETE
SAMPLE SEE THE FINAL
PAGES



BT01
TUBO TONDO BIANCO
SEMILUCIDO
SEMIGLOSSY WHITE ROUND
TUBE



BT72
TUBO TONDO METALLO
CROMATO
SEMIGLOSSY CHROMED
METAL ROUND TUBE



Aria Easy Art. 7204 BT01 501
Sedia impilabile in stampato
polimerico bianco lucido e
struttura in tinta.
Stackable chair in white
polymeric print and matching
structure.

OSLO

design by Studio 28

SGABELLO OSLO ART. T6319

*Sgabello girevole con meccanismo di alzata, struttura in freeform-tech e base in metallo cromato.
Dalla forma di un petalo nasce uno sgabello originale ed elegante come nello stile Tonin Casa.
Disponibile nelle colorazioni bianco e nero.*

*Swivel stool with hydraulic mechanism, structure in freeform-tech and chromed metal base.
The stool's concept is born from the idea of a petal, elegant yet original as Tonin Casa's style.
Available in white and black.*

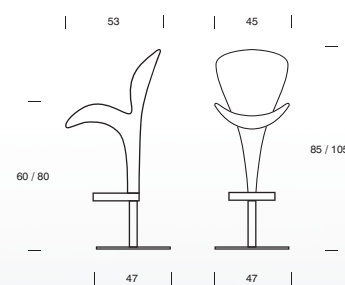

art. 6319

SEDUTA
SEAT

PER IL CAMPIONARIO
COMPLETO VEDI LE
PAGINE FINALI
FOR THE COMPLETE
SAMPLE SEE THE FINAL
PAGES



01
BIANCO OPACO
MATT WHITE



02
NERO OPACO
MATT BLACK



Oslo_Art. 6319 01
Sgabello girevole in
freeform-tech bianco.
Swivel stool in white
freeform-tech.

REAL

design by **Nicola Tonin**

SGABELLO REAL ART. T6307

Sgabello girevole con meccanismo di alzata e base in metallo cromato. La seduta è rivestita in vero cuoio e garantisce ottimo comfort oltre che un grande senso estetico. Ideale anche per forniture contract.

Swivelling stool with hydraulic mechanism and chromed metal base. The seat is covered in real thick leather, stunning comfort combined with a beautiful aesthetic concept. Ideal for contract supplies.

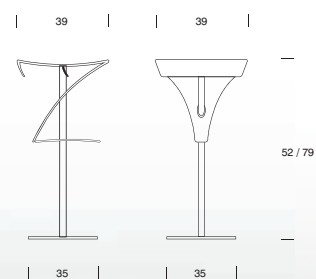

art. 6307

SEDUTA
SEAT

PER IL CAMPIONARIO
COMPLETO VEDI LE
PAGINE FINALI
FOR THE COMPLETE
SAMPLE SEE THE FINAL
PAGES



K01
BIANCO
WHITE

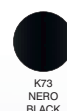

K73
NERO
BLACK



Real_Art. 6307 K01/K73
Sgabello girevole in vero
cuoio bianco/nero.
Swivelling stool in white/
black thick leather.

MILANO

design by Studio 28

SGABELLO MILANO ART. T6317

*Sgabello girevole con meccanismo di alzata e base in metallo cromato.
La seduta è rivestita in vero cuoio e grazie allo schienale alto garantisce un'ottima postura,
nonché un prodotto di tendenza.*

*Swivelling stool with hydraulic mechanism and chromed metal base.
The seat is covered in real thick leather, and the tall backrest gives a perfect posture - plus,
you have a trendy design object!*

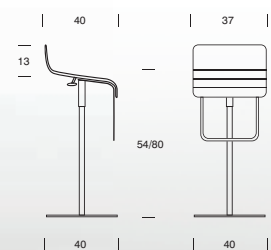

art. 6317

RIVESTIMENTI
COVERING

COMPLETO VEDI LE
PAGINE FINALI
FOR THE COMPLETE
SAMPLE SEE THE FINAL
PAGES

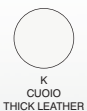

K
CUOIO
THICK LEATHER



K922
NATURALE NUBOLATO
NATURALLY CLOUDED



Milano_Art. 6317 K91
Sgabello girevole in cuoio
testa di moro.
Swivel stool in dark brown
thick leather.

NEW YORK

design by Studio 28

SGABELLO NEW YORK ART. T6316

*Sgabello girevole con meccanismo di alzata e base in metallo cromato.
La seduta imbottita e rivestita in cuoio garantisce un grande comfort.*

*Swivelling stool with hydraulic mechanism and chromed metal base.
The padded seat covered in thick leather gives you the best comfort.*

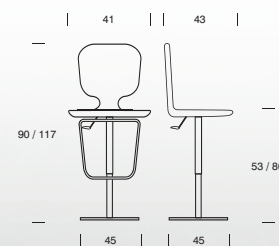

art. 6316

RIVESTIMENTI
COVERING

COMPLETO VEDI LE
PAGINE FINALI
FOR THE COMPLETE
SAMPLE SEE THE FINAL
PAGES

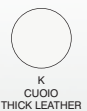

K
CUIO
THICK LEATHER



KN32
NATURALE NUVOLATO
NATURALLY CLOUDED



New York_Art. 6316 K01/K91
Sgabelli girevoli in vero cuoio
bianco e testa di moro.
Swivelling stools in white and
dark brown thick leather.

ASOLA

design by **Studio Tonin Creatives**

POLTRONA POUF ASOLA ART. T7303

*Poltrona pouf con imbottitura in miscela di perle di polistirene espanso, rivestita in ecopelle.
Dinamica e facile da inserire in ogni ambiente domestico rappresenta un vero "must" di Tonin Casa.*

*Eco-leather covered pouf / armchair, stuffed with a mix of polystyrene beads.
Dynamic and easy to fit into any domestic ambient, it's a true Tonin Casa "must".*

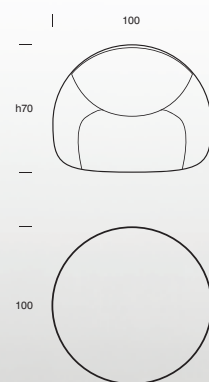

art. 7303

FINITURE BASE
BASE FINISHING

PER IL CAMPIONARIO
COMPLETO VEDI LE
PAGINE FINALI
FOR COMPLETE
SAMPLES SEE THE FINAL
PAGES



Asola_Art. 7303 S51/S59
Poltrone in ecopelle fango
e giallo senape.
Eco-leather armchairs in
mud and yellow mustard.

TRULY

design by Studio Tonin Creatives

POUF TRULY ART. T7300

*Pouf con imbottitura in miscela di perle di polistirene espanso, rivestito in ecopelle.
Morbidezza estrema per un articolo giovane e dinamico da personalizzare con il colore preferito.*

*Eco-leather covered pouf, stuffed with a mix of polystyrene beads.
Utmost softness to create a young and dynamic article you can customize in your favourite colour.*

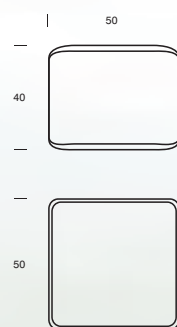

art. 7300

FINITURE
RIVESTIMENTO
COVERING FINISHING

PER IL CAMPIONARIO
COMPLETO VEDI LE
PAGINE FINALI
FOR COMPLETE
SAMPLES SEE THE FINAL
PAGES

S
ECOPELLE
ECO LEATHER



Truly_Art. 7300 S01/S40/S44
Pouff quadro in ecopelle
bianca, blu turchese e blu
notte.
Square eco-leather pouf in
white, turquoise blue and night
blue.

contenitori:
Programmi e madie
storage units:
systems
and sideboards

Honey
Paris
Venice
Granada
Miami
Asia
Goya



Programma HONEY

design by **Nicola Tonin**

PROGRAMMA HONEY ART. T6111/6112/6113/6114/6115

*Dal concetto di alveare nasce Honey, realizzata con elementi decorativi in legno applicati su fondo a specchio.
Un lavoro da mastro artigiano che si concretizza in vero design ispirazione anni '50.*

*The concept for the Honey program came from the beehive, manufactured with wood decorating elements placed on an underlying mirrored surface.
An artisan piece that translates into pure '50s and mid-century inspired design.*



Honey Art. 6111 01 01
Madia laccata bianco, 2 ante effetto specchio ed elementi bianchi, telaio in metallo verniciato bianco.
Sideboard 2 doors in wood with matt white lacquered decorations.

Programma HONEY

design by Nicola Tonin

Decorazioni in legno che creano un movimento morbido ma deciso fanno di Honey una madia unica nel suo genere; un brevetto ornamentale firmato Tonin Casa.

Wood decorations create a movement which is soft but with attitude, making Honey a sideboard that's one-of-a-kind; an ornamental patent with the Tonin Casa signature.



Honey_Art. 6112 14 02
Madia in noce canaletto, 3 ante effetto specchio con elementi in massello, telaio in metallo verniciato nero.
Sideboard 3 doors in canaletto walnut mirror effect and solid wooden elements, structure in lacquered black metal.

Programma HONEY

design by Nicola Tonin



MADIA SIDEBOARD

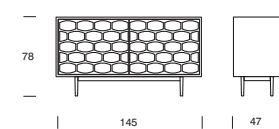

art. 6111

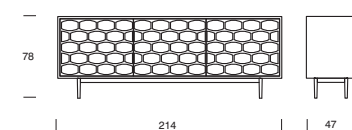

art. 6112

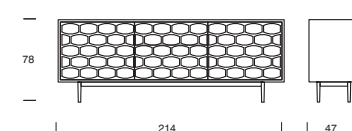

art. 6113

PORTA TV TV STAND

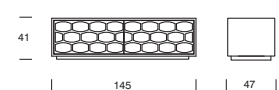

art. 6114

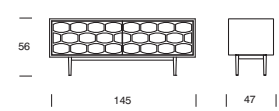

art. 6114H

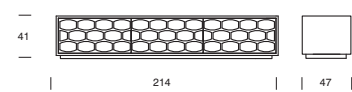

art. 6115

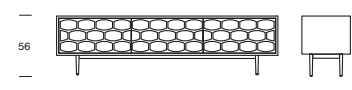

art. 6115H

FINITURE STRUTTURA STRUCTURE FINISHING



BASE METALLO METAL STRUCTURE



Honey_Art. 6155H 16 72

Porta tv in rovere scuro termotrattato, con 3 cassettoni effetto specchio ed elementi in massello. Telaio in metallo cromato.

TV Stand in thermo treated dark oak with 3 large drawers mirror effect and solid wooden elements. Chromed structure.

Programma PARIS

design by Studio 28

PROGRAMMA PARIS ART. T6023/6025/8350/8351/8352/8353/8355/8356/8359/8361/
8362/8363/8371/8372/8373/8381/8382/8383

*Un programma di contenitori realizzato in MDF microgoffrato con antine laserate con vetro temperato e maniglie in Swarovski®.
Un disegno arabeggiante rende unico ed elegante Paris, un solo elemento di questo programma arreda con gusto ed estrema classe ogni casa.*

*A program made of storage units manufactured in micro-embossed MDF with laser technique cut doors, tempered glass and Swarovski® doorknobs.
A design reminiscent of Arabic motifs that makes this collection unique and elegant, just one single module
from the Paris Program furnishes with taste and class any environment.*



Paris_Art. 8355D 02V2
Madià con 3 ante traforate e 3
cassetti in legno laccato nero
opaco con vetro temperato nero.
Sideboard with 3 fretted doors and
3 drawers in matt black lacquered
wood with black tempered glass.

Paris_Art.8355D 01 V101
Madia con 3 ante traforate e 3 cassetti in legno laccato bianco opaco con vetro temperato extra chiaro bianco.

Sideboard with 3 fretted doors and 3 drawers in matt white lacquered wood with tempered extraclear white glass.



Lavorazioni laser del legno ad altissima precisione, laccatura microgoffrata per avere la massima qualità, maniglie in Svarovski® e ripiani in vetro temperato per non lasciare nulla al caso.

High precision laser carving, micro goffered lacquering to achieve maximum quality, Svarovski® handles and tempred glass shelving to leave nothing to chance.

Paris_Art. 8373DV 01 V81
Vetrina 4x3 ante traforate in legno laccato bianco opaco.
Showcase 4x3 fretted doors in matt white lacquered wood.



Programma PARIS

design by Studio 28

Il made in Italy si concretizza nella scelta dei materiali e nelle tecniche di lavorazione per diventare scenografia pura.

Made in Italy becomes tangible in the choice of raw materials and in the manufacturing techniques, to transform objects into pure scenery



Paris_Art. 8371DV 02 V81
Vetrina 2x3 ante traforate in legno laccato nero opaco.

Showcase 2x3 fretted doors in matt black lacquered wood.

Bexley_Art. 8029 502 V2RS
Tavolo fisso con gambe in agglomerato di marmo laccato nero e piano sagomato in vetro temperato nero.

Fixed table with legs in agglomerate of marble lacquered black and profiled top in black tempered glass.

Vivienne_Art. 7258 S02
Sedia rivestita in ecopelle nera.
Chair covered in black eco-leather.



Paris_Art. 8361DV 60 V81
 Vetrina 2x2 ante traforate in
 legno laccato champagne
 opaco.
 Showcase 2x2 fretted doors
 in matt champagne lacquered
 wood.

*Paris è un programma
 modulare che ti permette
 di avere delle vetrine su
 misura che arredano
 anche gli spazi più piccoli.*

*Paris is a modular
 program that allows to
 have smaller cabinets to
 decorate even smaller
 spaces.*



Paris_Art. 8361DV 02 V81
 Vetrina 2x2 ante traforate in legno
 laccato nero opaco.
 Showcase 2x2 fretted doors in matt
 black lacquered wood.

Programma PARIS

design by Studio 28

MENSOLA SHELF

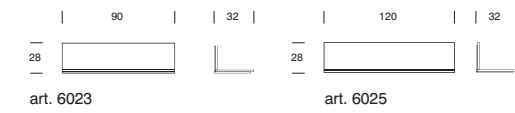

MADIA SIDEBOARD

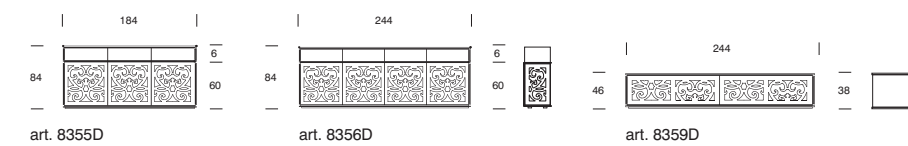

PORTA TV TV-STAND

VETRINE E PENSILI SHOWCASES

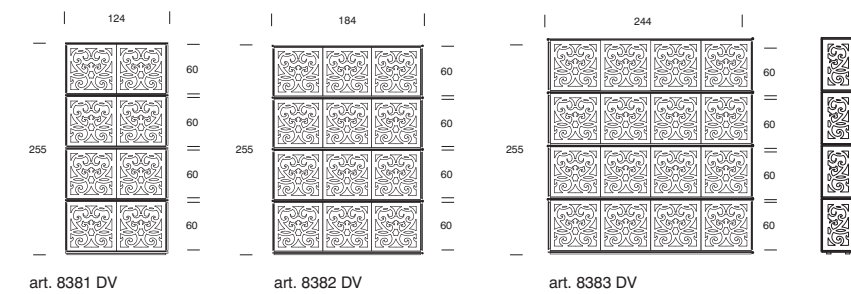
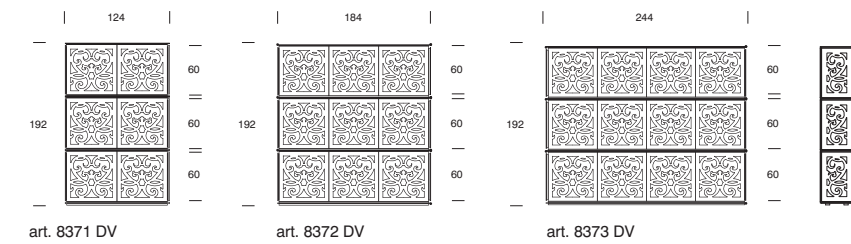
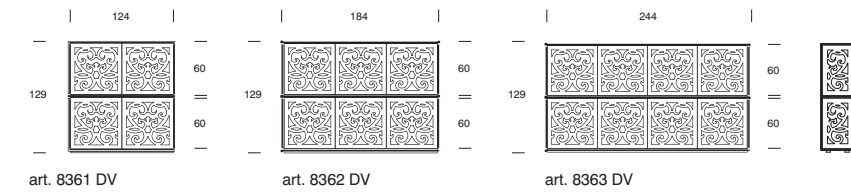
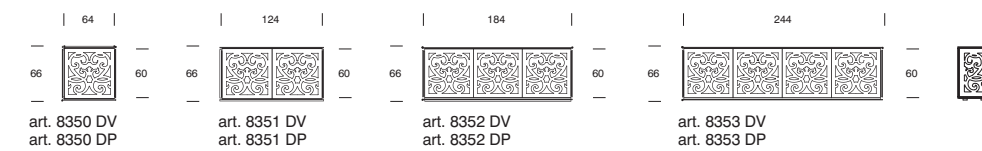

FINITURA STRUTTURA STRUCTURE FINISHING



FINITURA SCHIENALE VETRINE (OPZIONALE) FINISHING OF SHOWCASE BACK PANEL (OPTIONAL)



FINITURA ANTE IN VETRO PER MADIE E PORTA TV FINISHING OF SIDEBOARDS AND TV STAND GLASS DOORS



OPTIONAL FARETTI A LED OPTIONAL LIGHT LED



Paris_Art. 8359D 02 V2

Porta TV con cassettoni traforati in legno laccato nero opaco.

TV stands with fretted drawers in matt black lacquered wood.

Programma VENICE

design by Studio 28

PROGRAMMA VENICE ART. T8250/8252/8253/8254/8257/8258/8264/8261

Un programma di contenitori realizzato in MDF microgoffrato con ante lavorate e vero massello per la versione noce canaletto, con ante studiate per ottenere un effetto capitoné estremamente morbido. Il dettaglio fa la differenza, ed è per questo che tutti i top di Venice sono in vetro temperato ed anche i ripiani interni sono tutti in vetro, ciò per non lasciare nulla al caso.

A program made of storage units manufactured in micro-embossed MDF with manufactured doors for a very "soft" capitoné feel using solid wood for the canaletto walnut version. The difference is in the details, this is why all the tops of the Venice collection are in tempered glass, as well as the internal shelves.



Venice_Art. 8252 14 V2
Madia con 2 ante e 3 cassetti in vero legno massello noce canaletto capitoné; top in vetro temperato nero e base in metallo cromato.

Sideboard with 2 doors and 3 drawers in canaletto walnut capitoné; top in black tempered glass and base in chromed metal.

Ricciolo_Art. 7865 P46
Chaiselongue/poltrona in pelle verde pino.
Chaise-longue in pine green leather.

Programma VENICE

design by Studio 28



Venice_Art. 8252H 02 V2
Madia con 2 ante e 3 cassetti in legno capitoné laccato nero opaco; top in vetro temperato nero e base in metallo cromato.
Sideboard with 2 doors and 3 drawers in matt black lacquered capitoné wood; top in tempered black glass and base in chromed metal.

Lavorazioni di altissimo livello per ottenere un effetto capitoné morbido e delicato. Venice è un programma senza tempo.

Top quality manufacturing to obtain a soft and delicate capitoné effect. Venice is a timeless program.



Venice_Art. 8252H 01 V101
Madia con 2 ante e 3 cassetti in legno capitoné laccato bianco opaco; top in vetro temperato extrachiaro bianco e base in metallo cromato.
Sideboard with 2 doors and 3 drawers in matt white lacquered capitoné wood; top in tempered white extraclear glass and base in chromed metal.

Programma VENICE

design by Studio 28



Venice_Art. 8264 01 V101
Tavolino con cassetto in legno
capitoné laccato bianco opaco.
Coffee table with drawer in matt white
lacquered capitoné wood.

Il programma Venice prevede credenze ma anche tavolini disponibili in svariate colorazioni per adattarli ad ogni gusto e ad ogni ambiente.

The Venice program includes not only sideboards, but also coffee tables available in different colours, to adapt to any taste and any ambient.



Venice_Art. 8258 02 V2
Porta TV con cassettoni in legno
capitoné laccato nero opaco.
TV Stand with drawers in matt black
lacquered capitoné wood.

Programma VENICE

design by Studio 28

MADIA SIDEBOARD

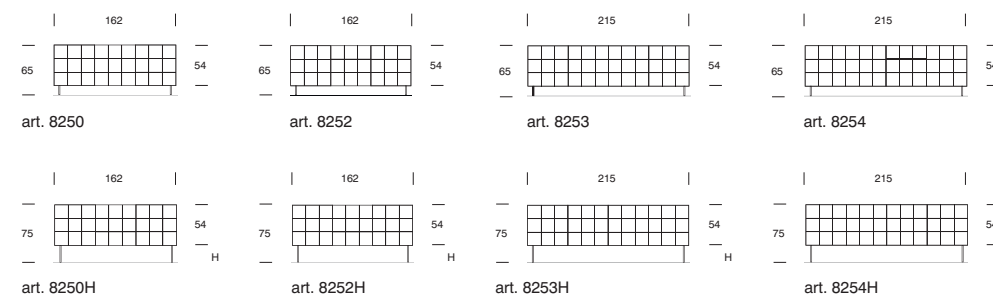

BOX

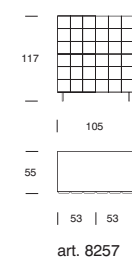

PORTA TV TV STAND

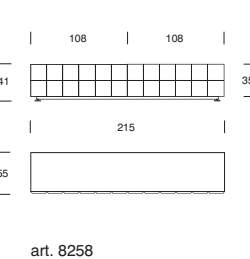

TAVOLINO QUADRATO SQUARE COFFEE

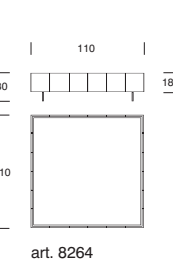

SPECCHIERA QUADRATA MIRROR SQUARE

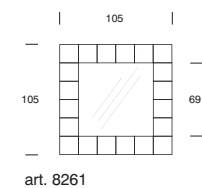

FINITURA STRUTTURA FINISHING STRUCTURE



FINITURA TOP IN VETRO GLASS TOP FINISHING



FINITURA SPECCHIERA MIRROR STRUCTURE FINISHING



La cura nel dettaglio si trova anche nei meccanismi push pull di questa collezione. Tutto viene progettato per avere il massimo della funzionalità senza rinunciare al design.

The care for details can be found also in the push pull mechanism of this collection. Everything is designed for maximum functionality



Venice_Art. 8257 60 V160
Box 4 ante in legno capitonné laccato champagne opaco; top in vetro temperato extrachiario champagne e base in metallo cromato.
Sideboard box with 4 doors in matt champagne lacquered wood; top in tempered extraclear champagne glass and base in chromed metal.

Programma GRANADA

design by **Angelo Tomaiuolo**

PROGRAMMA GRANADA ART. T8600/8601/8602/8603/8605/8606/8607/8608/8609/8610/ 8611/8612/8613

*Un programma di vetrine e credenze di estrema eleganza.
Strutture in legno, ante di cristallo serigrafato e maniglie Swarovski®
per un design haute couture senza tempo.*

*A program of refined and elegant glass cabinets and sideboards.
Wooden structure, doors in glass with serigraphy and Swarovski®
doorknobs for a timeless haute couture design.*



Granada_Art.8603H 14 V84B
Madia 3 ante e 3 cassetti in noce
canaletto e vetro trasparente
bronzato serigrafato.
*Sideboard 3 doors and 3 drawers
in canaletto walnut and etched
bronzed glass with serigraphy.*

Programma GRANADA

design by Angelo Tomaiuolo

Ante decorate, maniglie ispirate a preziosi diamanti, è tempo di cambiamento: il design si trasforma in gioiello.

Precious details, decorated doors, handles inspired from precious diamonds, it is time for change: design is transformed in jewels.

Granada_Art.8602 16 V84A

Madia 4 ante in rovere scuro termotrattato e vetro acidato bronze serigrafato.

Sideboard 4 doors in dark oak thermo treated and etched bronzed glass with serigraphy.





Granada_Art. 8605 14 V84B
Vetrina in noce canaletto 2x2
con ante in vetro trasparente
bronzato e serigrafato. Maniglie
Swarovski®.
Showcase 2x2 in canaletto
walnut with doors in transparent
bronzed glass with serigraphy.
Knobs in Swarovski®.

Un programma di vetrine e credenze di estrema raffinatezza. Strutture in legno, antine di cristallo serigrafato e maniglie Swarovski® per un design haute couture senza tempo.

An extremely elegant program of cabinets and sideboards of refined elegance. Wooden structures, serigraphy glass doors and handles in Swarovski® crystals, for a "haute couture" timeless design.

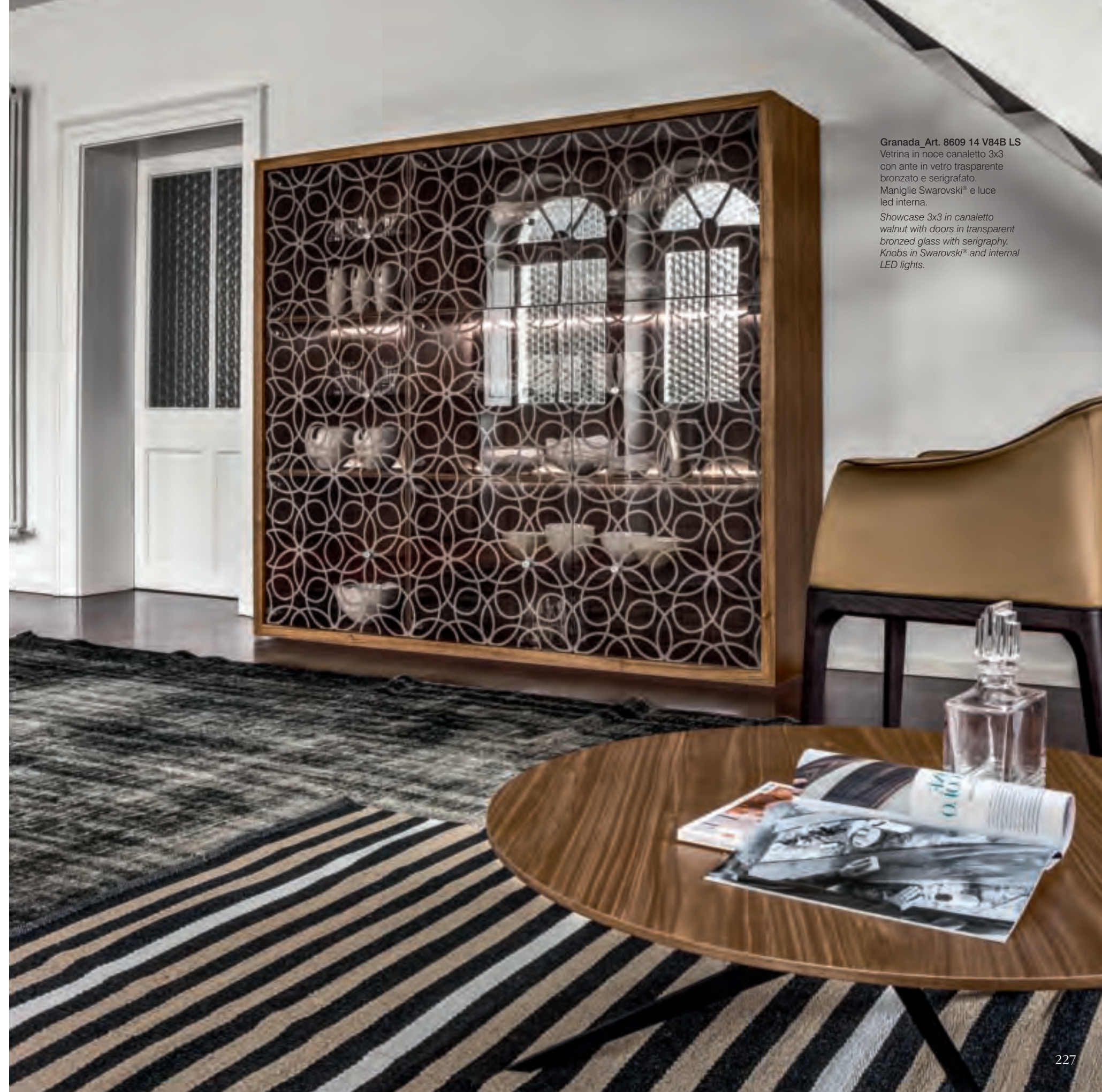

Granada_Art. 8609 14 V84B LS
Vetrina in noce canaletto 3x3
con ante in vetro trasparente
bronzato e serigrafato.
Maniglie Swarovski® e luce
led interna.
Showcase 3x3 in canaletto
walnut with doors in transparent
bronzed glass with serigraphy.
Knobs in Swarovski® and internal
LED lights.

Programma GRANADA

design by Angelo Tomaiuolo

MADIE SIDEBOARDS

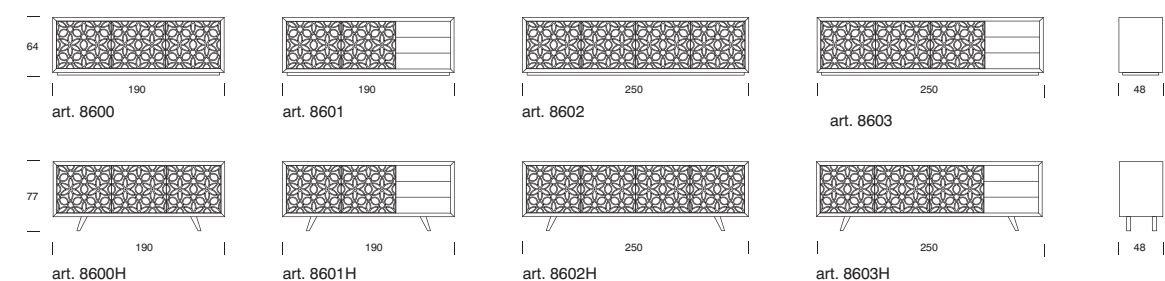

VETRINE SHOWCASES

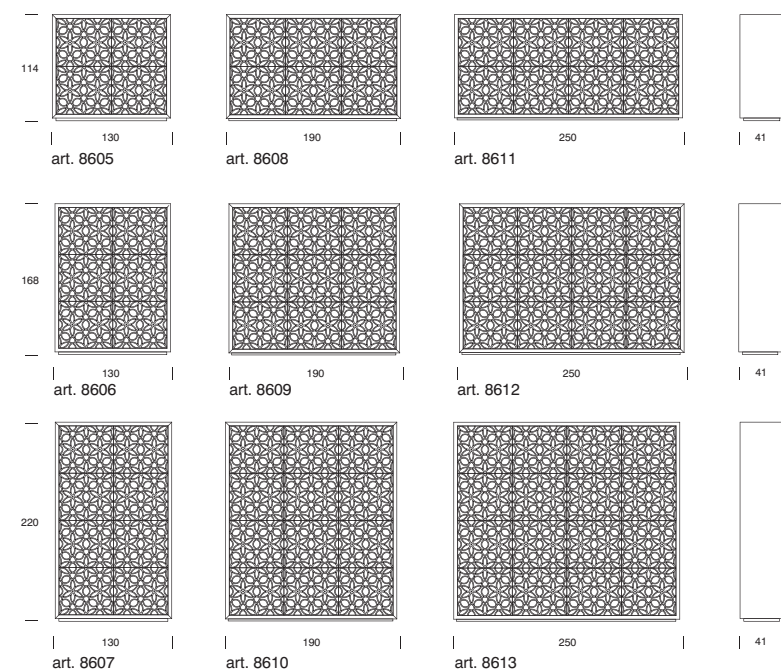

FINITURE STRUTTURA FINISHING STRUCTURE



14
NOCE CANALETTO
CANALETTO WALNUT



16
ROVERE SCURO
TERMOTRATTATO
DARK OAK HEAT-TREATED

FINITURE ANTE VETRO GLASS DOORS FINISHING



V84B
TRASPARENTE BRONZE
SERIGRAFATO
TRANSPARENT BRONZE GLASS
WITH SERIGRAPHY



V84A
ACIDATO BRONZE
SERIGRAFATO
ETCHED BRONZE GLASS WITH
SERIGRAPHY

OPTIONAL FARETTI A LED - OPTIONAL LIGHT LED



Granada Art. 8606 16 V84B LS
Vetrina in rovere scuro 2x3 con
ante in vetro trasparente bronzato
e serigrafato. Maniglie Swarovski[®]
e luce led interna.

Showcase in dark oak with doors
in transparent bronze glass with
serigraphy. Knobs in Swarovski[®]
and internal LED lights.

Programma MIAMI

design by **Studio 28**

PROGRAMMA MIAMI ART. T6204/6205/6211

Un programma di contenitori realizzato con profilo anteriore interamente in alluminio, telai in metallo cromato e struttura in vetro temperato acidato. Per Miami solo materiali di prim'ordine e di grande qualità per avere un prodotto di massimo prestigio tecnico ed estetico.

A program made of storage units manufactured with the front profile entirely made in aluminium, while the frame is made in chromed metal and the structure in etched tempered glass. For Miami only first class quality materials have been involved, in order to give you a product with is the top both technically and in the appearance.



Miami_Art.6211 02 V81
Vetrina con profilo anteriore in alluminio laccato nero, ante e ripiani temperati trasparenti.
Showcase with front profile in black lacquered aluminium, doors and shelves in transparent tempered glass.

Programma MIAMI

design by Studio 28

Il pregio dell'alluminio e la tendenza dei vetri acidati opachi rendono il programma Miami inconfondibile.

The quality of aluminium and the modern touch given by etched glass makes the program Miami both unmistakable and unique.



Miami_Art. 6204 02 V602
Madia 4 ante con profilo anteriore
in alluminio laccato nero, vetri
acidati neri.
Four door cabinet with front profile
in black lacquered aluminium,
black etched glasses.

Programma MIAMI

design by Studio 28



MADIA 4 ANTE - telai in tinta
SIDEBOARD WITH 4 DOORS - frame in the same color

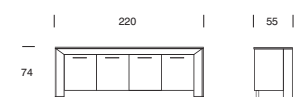

art. 6204

PORTA TV
TV-STAND

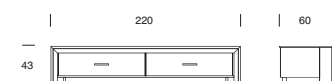

art. 6205

VETRINA - telaio cromato con 2 faretti led di serie
BOOKCASE / SHOWCASE - WITH 2 LED LIGHT STANDARD - telaio cromato - chromed structure

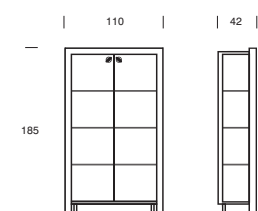

art. 6211

FINITURE STRUTTURA
STRUCTURE
FINISHING

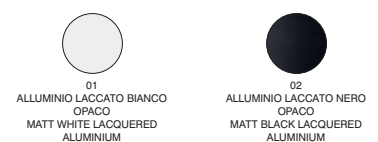

FINITURE VETRO
GLASS FINISHING

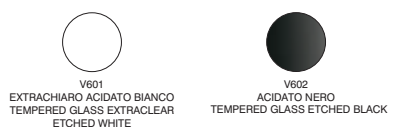

FINITURE VETRO
VETRINA
GLASS FINISHING OF
SHOWCASE



Miami_Art. 6204 02 V602
Madia 4 ante con profilo anteriore
in alluminio laccato nero, vetri
acidati neri.

Four door cabinet with front
profile in black lacquered
aluminium, black etched glasses.

ASIA

design by **Studio Tonin Casa Creatives**

MADIA ASIA ART. T6120

*Madia ellittica in legno con ante e fianchi in vetro curvo. Disponibile in diverse finiture.
Forme arrotondate e morbide per una madia che arreda con gusto e distinzione.*

*Elliptical wooden buffet with sides and doors in curved glass. Available in different finishing.
Rounded smooth shapes define this sideboard that furnishes with taste and distinction.*



Asia Art. 6120 14 V2
Madia ellittica in noce canaletto
con ante e fianchi in vetro curvo
nero.

*Elliptical sideboard in canaletto
walnut with doors and sides in
black curved glass.*

ASIA

design by **Studio Tonin Casa Creatives**

L'Attenzione ad ogni particolare fa la differenza: finitura interna in noce con ripiani in vetro extra chiaro trasparente.

Care for every detail is what makes the difference : internal finish in walnut and shelves in extra clear transparent glass

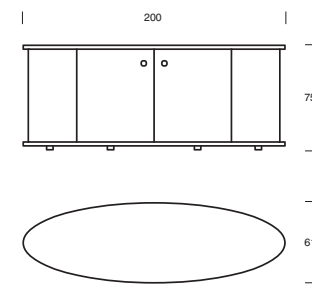

art. 6120

FINITURE
STRUTTURA
STRUCTURE
FINISHING



01
BIANCO OPACO
MATT WHITE



14
NOCE CANALETTO
CANALETTO WALNUT



16
ROVERE SCURO
TERMOTRATTATO
DARK OAK HEATTREATED

FINITURE
ANTE
DOORS
FINISHING



V2
NERO
BLACK



V101
EXTRA CHIARO BIANCO
EXTRA CLEAR WHITE

Asia_Art. 6120 14 V2
Madia ellittica in noce canaletto con ante e fianchi in vetro curvo nero.

Elliptical sideboard in canaletto walnut with doors and sides in black curved glass.



GOYA

design by **Studio 28**

MADIA GOYA ART. T6107

Madia realizzata in MDF microgoffrato laccato opaco. Goya è perfetta per chi vuole praticità e massima qualità. L'apertura coplanare, infatti, permette di ottimizzare gli spazi senza rinunciare al design. Disponibile anche con kit luce.

Sideboard manufactured in matt lacquered micro-embossed MDF. Goya is perfect for those looking for practicality and top quality at the same time. The coplanar opening enables to rationalize your space without giving up on design. Available also with lighting kit.



Goya Art. 6107 51
Madia coplanare laccata
fango opaco.
Sideboard with sliding
doors in matt mud.



GOYA

design by Studio 28



art. 6107

FINITURE
STRUTTURA
STRUCTURE
FINISHING



01
BIANCO OPACO
MATT WHITE



02
NERO OPACO
MATT BLACK



36
BEIGE OPACO
MATT BEIGE



51
FANGO OPACO
MATT MUD

OPTIONAL LUCE A LED *OPTIONAL LIGHT LED*



Goya_Art. 6107 02
Madia complanare laccata
nero opaco.
Sideboard with sliding
doors in matt black.

contenitori:
Librerie e vetrine
storage units:
bookcases
and showcases

Abaco
Naviglio
Osuna
Trafalgar
Aurora
Oregina
Gracia
Olivella
Parella



ABACO

design by **Andrea Lucatello**

LIBRERIA ABACO ART. T7243

*Libreria ad elementi modulari che permettono di personalizzarla ed adattarla ai propri ambienti.
Realizzata in MDF laccato presenta degli inserti in noce canaletto o rovere scuro con schienale lucido che la rendono originale e dinamica.*

*Bookshelf made out of modular elements that enable customizing in order to adapt it to your own space.
Manufactured in lacquered MDF, inserts of canaletto walnut and dark oak make it original and dynamic.*



Abaco_Art. 7243 01 14 14
Libreria modulare laccata bianca con
inserti in noce canaletto.
Modular bookshelf lacquered white
with canaletto walnut inserts.

ABACO

design by **Andrea Lucatello**

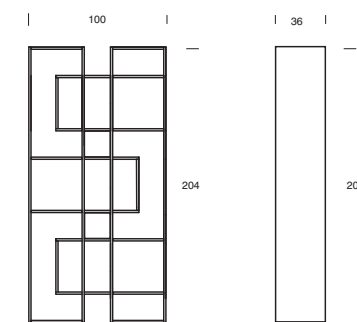

art. 7243

FINITURE ELEMENTI VERTICALI FINISHING VERTICAL ELEMENTS



01
BIANCO OPACO
MATT WHITE



02
NERO OPACO
MATT BLACK

FINITURE ELEMENTI ORRIZZONTALI FINISHING HORIZONTAL ELEMENTS



01
BIANCO OPACO
MATT WHITE



02
NERO OPACO
MATT BLACK



14
NOCE CANALETTO
CANALETTO WALNUT



16
ROVERE SCURO
TERMOTRATTATO
DARK OAK HEAT-TREATED



17
ROVERE NATURALE
NATURAL OAK

FINITURE CASSETTI E ANTE FINISHING DRAWERS AND DOORS



14
NOCE CANALETTO
CANALETTO WALNUT



16
ROVERE SCURO
TERMOTRATTATO
DARK OAK HEAT-TREATED



17
ROVERE NATURALE
NATURAL OAK

Abaco_Art. 7243 01 01
Libreria laccata bianca.
Bookshelf lacquered white.

NAVIGLIO

design by **Nicola Tonin**

LIBRERIA NAVIGLIO ART. T7247

*Libreria realizzata con un intreccio di fili metallici laccati che sostengono dei ripiani in vetro o in legno.
Naviglio è caratterizzata da un disegno deciso ed intramontabile perfetto per ogni ambiente.*

*Bookshelf made out of intertwining of metal threads that support tempered glass, canaletto walnut or dark oak shelves.
Naviglio features a timeless design with attitude, perfect for any ambient.*



Naviglio_Art. 7247 02 14
Libreria in metallo laccato nero e con ripiani in noce canaletto.
Bookcase in lacquered black metal with shelves in canaletto walnut.

NAVIGLIO

design by Nicola Tonin

Un'intreccio di fili dal design unico e leggero creano Naviglio.

Twine of wires form the unique and soft design of Naviglio.



Naviglio_Art. 7247 01 V101
 Libreria in metallo laccato bianco con ripiani in vetro extra chiaro bianco.
 Bookcase in lacquered white metal with shelves in white extraclear glass.

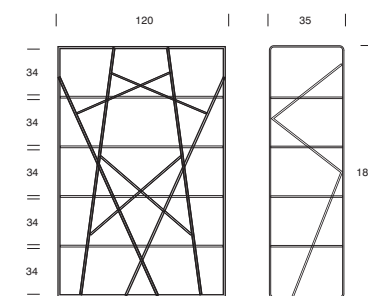

art. 7247

FINITURA STRUTTURA
 STRUCTURE FINISHING



FINITURE RIPIANI IN VETRO
 GLASS TOP FINISHING



FINITURE RIPIANI IN LEGNO
 WOOD TOP FINISHING



Naviglio_Art. 7247 01 17
 Libreria in metallo laccato bianco con ripiani in rovere naturale.
 Metal bookshelf lacquered white with shelves in natural oak.

OSUNA

design by **Studio 28**

LIBRERIA OSUNA ART. T7241

*Libreria girevole realizzata in MDF laccato o rivestito legno e con inserti a specchio.
Ideale per contenere sia libri che oggetti e rendere ogni casa unica ed inimitabile.*

*Swivelling bookshelf manufactured in lacquered MDF with mirrored inserts.
Ideal for both books or objects, in order to make any home unique and inimitable.*



Osuna_Art.7241 14
Libreria girevole in noce canaletto con
supporti finitura a specchio.
*Revolving bookcase in canaletto walnut
with mirror finish supports.*

Ricciolo_Art. 7865 P46
Chaiselongue/poltrona in pelle verde pino
Chaise-longue in pine green leather.

OSUNA

design by **Studio 28**



Osuna_Art.7241 02
Libreria girevole laccata nero opaco con supporti finitura a specchio.
Revolving bookcase lacquered matt black with mirror finish supports.

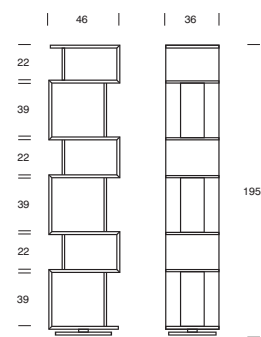

art. 7241

FINITURA
FINISHING



01
BIANCO OPACO
MATT WHITE



02
NERO OPACO
MATT BLACK



14
NOCE CANALETTO
CANALETTO WALNUT



15
ROVERE SCURO
TERMOTRATTATO
DARK OAK HEAT-TREATED

Forme geometriche impreziosite da inserti in finitura specchio che creano effetti di profondità e di luce.

Geometrical shapes embellished by mirrored inserts, creating effects of depth and light.

TRAFALGAR

design by Studio 28

LIBRERIA TRAFALGAR ART. T7246

*Libreria in legno con supporti in metallo cromato.
Un disegno geometrico dinamico in simbiosi alla qualità dei materiali fa sì che Trafalgar rappresenti uno dei prodotti intramontabili della collezione firmata Tonin Casa.*

*Wooden bookshelf with chromed metal supporting elements.
A dynamic geometrical design coupled with the quality of raw materials have turned Trafalgar into one of the everlasting Tonin Casa classics.*

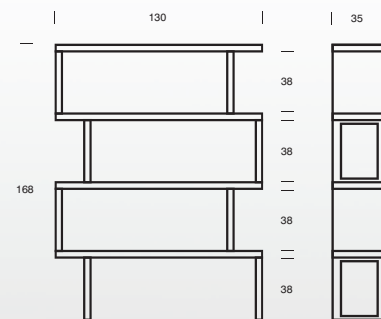

art. 7246

FINITURA
FINISHING



01
BIANCO OPACO
MATT WHITE



14
NOCE CANALETTO
CANALETTO WALNUT



16
ROVERE SCURO
TERMOTRATTATO
DARK OAK HEAT-TREATED



Trafalgar Art.7246 14
Libreria in legno rivestita noce canaletto;
supporti in metallo cromato.
*Wooden bookcase covered canaletto walnut;
chromed metal supports.*

AURORA

design by Studio 28

VETRINA AURORA ART. T6251/T6252

Vetrina con fianchi, schiena e ripiani in vetro temperato e struttura di supporto rivestita legno in diverse finiture. Dalla semplicità nasce Aurora una vetrina che si adatta agevolmente a tutti gli ambienti domestici. Disponibile anche con faretti.

Glass cabinet with sides, back panel and shelves in tempered glass and supporting structure wood veneered in different finishing. Aurora is a simple glass cabinet that easily adapts into any ambient in your home. Available also with internal led light spot..



Aurora Art. 6252 14
Vetrina 2 ante in legno noce
canaletto con ante e ripiani in
vetro trasparente.
Showcase 2 doors in canaletto
walnut with doors and shelves
in transparent glass.

AURORA

design by Studio 28

*La semplicità è
intramontabile...
così come lo è Aurora
realizzata solo con
legno e vetro.*

*Simplicity is
everlasting...and so is
Aurora, manufactured
just in wood and glass.*



Aurora_Art. 6251 16
Vetrina in legno rovere scuro
termotrattato con un'anta e
ripiani in vetro trasparente.
*Showcase 1 door in dark oak
thermo treated, with door and
shelves in transparent glass.*

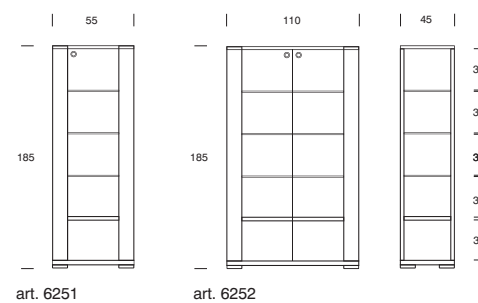

art. 6251

art. 6252

FINITURA STRUTTURA STRUCTURE FINISHING



24
BIANCO PORO APERTO
WHITE OPEN PORE



14
NOCE CANALETTO
CANALETTO WALNUT



16
ROVERE SCURO
TERMOTRATTATO
DARK OAK HEAT-TREATED

FINITURA VETRI GLASS FINISHING



V81
TRASPARENTE
TRANSPARENT

art. 6451 VETRINA CON 1 FARETTO LED DI SERIE SHOWCASE WITH 1 LED LIGHT STANDARD
art. 6452 VETRINA CON 2 FARETTI LED DI SERIE SHOWCASE WITH 2 LED LIGHT STANDARD

Aurora_Art. 6252 24
Vetrina 2 ante in legno laccato
bianco poro aperto con ante e
ripiani in vetro trasparente.
*Showcase 2 doors in white
lacquered wood with doors and
shelves in transparent glass.*



OREGINA

design by Studio 28

VETRINA OREGINA ART. T6418

Vetrina in legno con ante e schienale in vetro curvato. Disponibile in diverse finiture e con faretto.
Una forma scultorea per una vetrina che arreda ogni spazio all'insegna del design.

Wooden glass cabinet with doors and back panel in curved glass. Available in different finishing and with internal led light spot.
A sculptural shape for a glass cabinet that furnishes any corner with design.

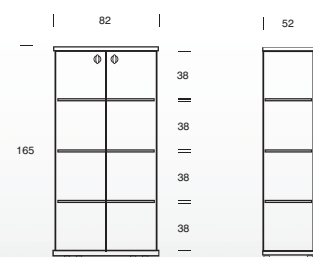

art. 6418

FINITURA STRUTTURA STRUCTURE FINISHING



01
BIANCO OPACO
MATT WHITE



02
NERO OPACO
MATT BLACK



14
NOCE CANALETTO
CANALETTO WALNUT



16
ROVERE SCURO
TERMOTRATTATO
DARK OAK HEAT-TREATED



35
SALVIA
SAGE



60
CHAMPAGNE OPACO
MATT CHAMPAGNE

VETRINA CON 1 FARETTO LED DI SERIE SHOWCASE WITH 1 LED LIGHT STANDARD



Oregina_Art. 6418 60
Vetrina in legno laccato champagne opaco con ante in vetro curvo e faretto led interno.
Glass cabinet in lacquered matt champagne wood with doors in curved glass and internal spotlight.

GRACIA

design by Studio 28

VETRINA GRACIA ART. T6430

Vetrina in legno con ante e schienale in vetro curvato. Disponibile in diverse finiture e con faretto.
L'eleganza del vetro curvo per risaltare la cristalleria più preziosa.

Wooden glass cabinet with doors and back panel in curved glass. Available in different finishing
and with internal led light spot. The elegance of curved glass to let your precious glassworks stand out.

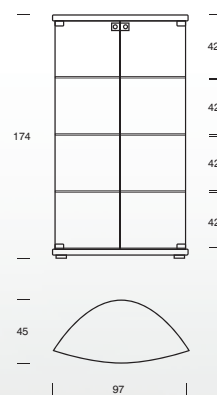

art. 6430

FINITURA STRUTTURA
STRUCTURE FINISHING



01
BIANCO OPACO
MATT WHITE



02
NERO OPACO
MATT BLACK



14
NOCE CANALETTO
CANALETTO WALNUT



16
ROVERE SCURO
TERMOTRATTATO
DARK OAK HEAT-TREATED



35
SALVIA
SAGE



60
CHAMPAGNE OPACO
MATT CHAMPAGNE

VETRINA CON 1 FARETTO LED DI SERIE SHOWCASE WITH 1 LED LIGHT STANDARD



Gracia_Art. 6430 01
Vetrina in legno laccato bianco opaco con ante in vetro curvo e faretto interno.
Showcase in matt white lacquered wood with curved glass doors and internal light.

OLIVELLA

design by Studio 28

VETRINA OLIVELLA ART. T6427

Vetrina in legno con ante e schienale in vetro curvato. Disponibile in diverse finiture e con faretto.
Ispirata ad una goccia d'acqua, Olivella è pensata per dare ancora più valore alla cristalleria.

Wooden glass cabinet with doors and back panel in curved glass.
Available in different finishing and with internal led light spot.
Inspired by the shape of a drop Olivella gives more value to your glassworks.

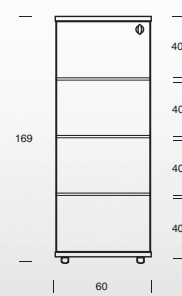

art. 6427

FINITURA STRUTTURA
STRUCTURE FINISHING



01
BIANCO OPACO
MATT WHITE



02
NERO OPACO
MATT BLACK



14
NOCE CANALETTO
CANALETTO WALNUT



16
ROVERE SCURO
TERMOTRATTATO
DARK OAK HEAT-TREATED



35
SALVIA
SAGE



60
CHAMPAGNE OPACO
MATT CHAMPAGNE

VETRINA CON 1 FARETTO LED DI SERIE SHOWCASE WITH 1 LED LIGHT STANDARD



Olivella_Art. 6427 35
Vetrina in legno laccato verde salvia con ante in vetro curvo e faretto interno.
Showcase in sage green lacquered wood with door in curved glass and internal light.

PARELLA

design by Studio 28

VETRINA PARELLA ART. T6429

Vetrina in legno con anta in vetro curvo. Disponibile in diverse finiture e con faretto.
Parella è una vetrina angolare perfetta per dare un tocco glamour ai piccoli spazi dell'ambiente domestico.

Wooden glass cabinet with door in curved glass. Available in different finishing and with internal led light spot.
Parella is a corner glass cabinet perfect to add glamorous touch to any small ambient in your home

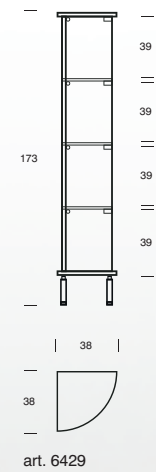

FINITURA STRUTTURA STRUCTURE FINISHING



01
BIANCO OPACO
MATT WHITE



02
NERO OPACO
MATT BLACK



14
NOCE CANALETTO
CANALETTO WALNUT



16
ROVERE SCURO
TERMOTRATTATO
DARK OAK HEAT-TREATED



35
SALVIA
SAGE



60
CHAMPAGNE OPACO
MATT CHAMPAGNE

VETRINA CON 1 FARETTO LED DI SERIE SHOWCASE WITH 1 LED LIGHT STANDARD



Parella_Art. 6429 01
Vetrina in legno laccato bianco opaco con anta in vetro curvo e faretto interno.
Showcase in matt white lacquered wood with curved glass door and internal light.

complementi:
Porta TV
tv stands

Cortes
Odeon



CORTES

design by Studio 28

PORTA TV CORTES ART. T7095 – T7095G

*Porta tv orientabile in legno con struttura in metallo, finitura alluminio e vetro temperato.
Disponibile in diverse finiture. Cortes permette di avere lateralmente anche uno spazio per contenere
i dvd e un appoggio in vetro per i diversi dispositivi.*

*Wooden revolving TV stand, metal structure with aluminium finish and tempered glass.
Available in different finishing. Cortes also has a lateral storage
for CDs or DVD and a glass support for the different electronic devices.*

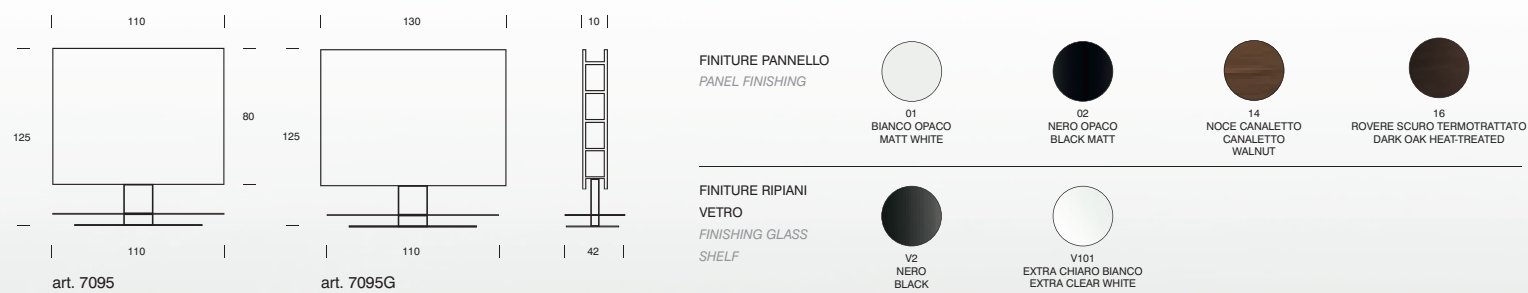

Cortes_Art. 7095 14 V2
Porta TV in noce canaletto e ripiano in vetro temperato nero.
TV Stand in canaletto walnut and shelf in black tempered glass.

ODEON

design by Studio 28

PORTA TV ODEON ART. T7098

*Porta tv orientabile in vetro curvo, con supporto in acciaio inox satinato.
L'estrema difficoltà di curvatura del vetro che caratterizza questo oggetto lo rende unico
nonché un prodotto storico di Tonin Casa.*

*Curved glass revolving TV stand, with satin stainless steel support.
The extreme difficulty given by the manufacturing of curved glass makes this object unique
and a Tonin Casa classic.*

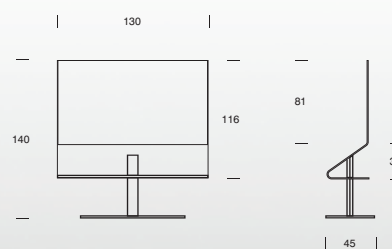

art. 7098

FINITURE
FINISHING



V2
NERO
BLACK



V101
EXTRA CHIARO BIANCO
EXTRA CLEAR WHITE



Cortes Art. 7098 V101

Porta TV orientabile in vetro curvato extra chiaro bianco e supporto in acciaio inox.

Swivel TV Unit in curved white extraclear glass with stainless steel support.

complementi:
Tavolini

*occasional
furniture
coffee tables*

*Dubai
Amira
Space
Tree
Arona
Osowa
Missouri
Central
Parioli
Tudor
Amburgo
Amanda
Amaranto
Anemone
Alaric
Alissa
Navile
Ariel
Pavones
Andorra
Detroit
Airone
Adachi
Diva
Fly*



DUBAI

design by Studio 28

TAVOLINO DUBAI ART. T6608

*Tavolino con base realizzata in agglomerato di marmo e piano in vetro temperato.
Disponibile anche con base finitura RAL per personalizzare gli ambienti a proprio gusto.
Dubai è l'unico originale, con brevetto depositato.*

*Coffee table with marble conglomerate base and tempered glass top.
Available also with the base in any RAL colour, to customize your ambient as you wish.
Dubai is the only original, with deposited patent.*



Dubai Art.6608 501 V101

Tavolino con base in agglomerato di marmo laccato bianco lucido e top in vetro extrachiaro temperato serigrafato bianco.

Coffee table with base in lacquered glossy white marble agglomerate and top in tempered extrachiar glass with white serigraphy.

DUBAI

design by **Studio 28**

Il salotto che vuoi con il RAL che desideri! Dubai è l'unico originale.. tutto il resto è una banale imitazione! Scegli sempre e solo prodotti originali e fabbricati in Italia!

The living room you wish, in whichever RAL colour you pick ! Dubai is the only original...the rest is just a pointless imitation. Always choose only original made in Italy products!



Dubai_Art.6608 502 V2
Tavolino con base in agglomerato di marmo laccato nero lucido e top in vetro temperato serigrafato nero.
Coffee table with base in lacquered glossy black marble agglomerate and top in tempered glass with black serigraphy.



Dubai_Art. 6608 RAL6034 V81
Tavolino con base in agglomerato di marmo in RAL blu turchese e top in vetro temperato trasparente.
Coffee table with base in marble conglomerate in RAL Turquoise blue and top in tempered transparent glass.

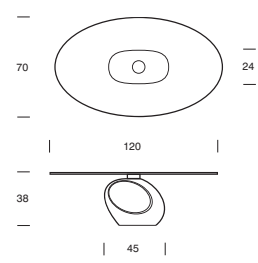

art. 6608

FINITURE BASE
BASE FINISHING



501
BIANCO LUCIDO
GLOSSY WHITE



502
NERO LUCIDO
GLOSSY BLACK



560
CHAMPAGNE LUCIDO
GLOSSY CHAMPAGNE



FINITURA RAL A
RICHIESTA
RAL FINISH ON
REQUEST

**FINITURE TOP VETRO
CON SERIGRAFIA**
TOP FINISHING WITH
GLASS SCREEN
PRINTING



V2
SERIGRAFATO NERO
GLASS WITH BLACK SILK-
SCREEN PRINTING



V101
EXTRA CHIARO SERIGRAFATO
BIANCO
GLASS WITH EXTRA CLEAR
WHITE SILK-SCREEN PRINTING



V160
EXTRA CHIARO SERIGRAFATO
CHAMPAGNE
GLASS WITH EXTRA CLEAR
CHAMPAGNE SILK-SCREEN
PRINTING

**FINITURE TOP IN
VETRO**
GLASS TOP
FINISHING



V81
TRASPARENTE
TRANSPARENT



V100
EXTRA CHIARO TRASPARENTE
EXTRA CLEAR TRANSPARENT

AMIRA

design by **Davide Bozzini**

TAVOLINI AMIRA ART. T6273/6274

*Serie di Tavolini con struttura in ceramica, disponibili in diverse finiture.
Allegri ed eleganti arredano con dinamicità e gusto ogni casa.*

*A series of occasional tables with ceramic structure, available in different finishing.
Cheerful and elegant, they furnish with dynamism and taste any household.*



Amira_Art.6273 303 14
Tavolino bicolore bianco e oro
lucido con top in noce canaletto.
*Side table two-coloured white
and gold with top in canaletto
walnut.*

Amira_Art.6274 303 14
Tavolino bicolore bianco e oro
lucido con top in noce canaletto.
*Side table two-coloured white
and gold with top in canaletto
walnut.*

AMIRA

design by **Daide Bozzini**

Note cromatiche bicolore per la base in ceramica abbinata a piani in legno disponibili in diverse finiture.

Bicolour chromatic notes for the ceramic base, matched with the wooden top available in different finishing.



Amira_Art.6274 302 14
Tavolino bicolore nero e oro lucido con top in noce canaletto.

Side table two-coloured black and gold with top in canaletto walnut.

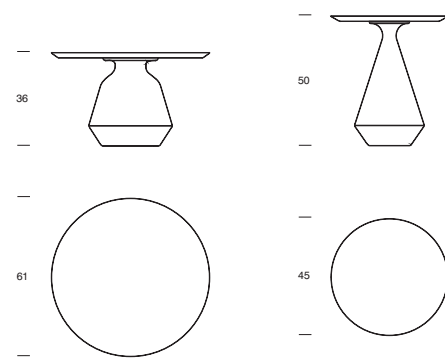

art. 6273

FINITURE TOP TOP FINISHING



FINITURE BASE BASE FINISHING



Amira ART.6273 301 17
Tavolino bicolore bianco e verde salvia opaco con top in rovere naturale.
Side table two-coloured white and matt sage with top in natural oak.

SPACE

design by **Diego Barbieri**

TAVOLINO SPACE ART. T6296/6297

*Tavolino e servetto a 3 piani, disponibile in diverse finiture.
Un movimento semplice ma funzionale che dona vivacità agli ambienti domestici.*

*Coffee table or end table with 3 separate levels, available in different finishing.
One simple yet functional movement furniture.*



Space_Art. 6297 A01
Tavolino con ripiani laccati
bianco opaco e struttura in
metallo verniciato bianco
opaco.

*Coffee table with matt
white lacquered shelves
and structure in matt white
lacquered metal.*

SPACE

design by **Diego Barbieri**



Scegli la combinazioni di piani che preferisci. Rendi originale il tuo tavolino space.

Chose the top you prefer, turn your Space into something creative.

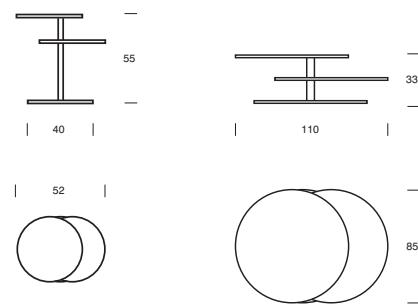

art. 6296

art. 6297

versione A: MONOCOLORE, 3 RIPIANI LACCATI COLORI DISPONIBILI:
version A: MONOCOLOR VERSION, 3 LACQUERED SHELVES COLORS AVAILABLE:



versione B: BICOLORE, 2 RIPIANI LACCATI E TOP NOCE CANALETTO COLORI DISPONIBILI PER I RIPIANI:
version B: BICOLOUR VERSION, 2 LACQUERED SHELVES AND CANALETTO WALNUT TOP SHELVES COLORS AVAILABLE:



versione C: LEGNO, 3 RIPIANI IN NOCE CANALETTO UNICA FINITURA DISPONIBILE:
version C: WOOD VERSION, 3 SHELVES IN CANALETTO WALNUT ONLY FINISH AVAILABLE:



Space_Art. 6297 B02
Tavolino con ripiani laccati nero opaco, top in noce canaletto e struttura in metallo verniciato nero opaco.
Coffee table with matt black lacquered shelves, top in canaletto walnut and structure in matt black lacquered metal.

Space_Art. 6296 A59
Tavolino con ripiani laccati giallo senape opaco e struttura in metallo verniciato giallo senape opaco.
Side table with matt yellow mustard lacquered shelves and structure in matt yellow mustard lacquered metal.

TREE

design by **Diego Barbieri**

TAVOLINO TREE ART. T6298/6299

Tavolino e servetto con struttura in lamina e piano disponibile in diverse finiture.

Tree è una collezione di tavolini di diverse altezze, preziosi ma semplici elementi che arredano con grazia la casa.

Coffee table or end table with laminate structure and top available in different finishing.

Tree is a collection of occasional tables with different heights, simple but precious element that furnish the household with grace.



Tree_Art.6299 40 14

Tavolino con piano in noce canaletto e struttura in metallo verniciato blu turchese.

Side table with top in canaletto walnut and structure in lacquered turquoise metal.

Tree_Art.6299 01 01

Tavolino con piano laccato bianco opaco e struttura in metallo verniciato bianco opaco.

Side table with top lacquered matt white and structure in lacquered matt white metal.

TREE

design by **Diego Barbieri**

Ogni mobile al posto giusto! Il design perfetto per ogni circostanza! Belli da abbinare anche in coppia.

Every piece of furniture in its right place! The perfect design for any circumstance! Beautiful when matched together.



Tree_Art.6298 02 14

Tavolino con piano in noce canaletto e struttura in metallo verniciato nero opaco.
Coffee table with top in canaletto walnut and structure in lacquered matt black metal.

Tree_Art.6299 02 14

Tavolino con piano in noce canaletto e struttura in metallo verniciato nero opaco.
Side table with top in canaletto walnut and structure in lacquered matt black metal.

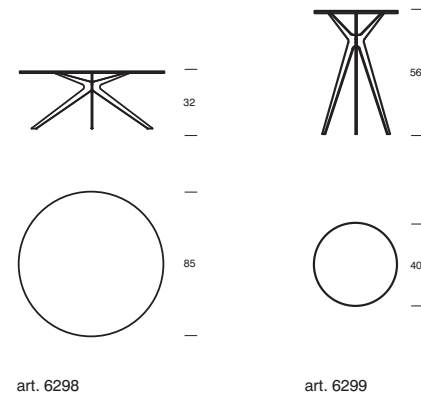

art. 6298

art. 6299

FINITURE BASE
BASE FINISHING



FINITURE PIANO
TOP FINISHING

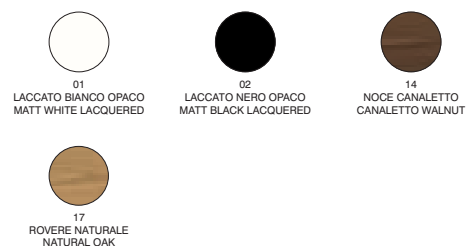

Tree_Art. 6298 01 17

Tavolino con piano in rovere naturale e struttura in metallo verniciato bianco opaco.
Coffee table with natural oak top and structure in matt lacquered white metal.

Tree_Art. 6299 01 17

Servetto con piano in rovere naturale e struttura in metallo verniciato bianco opaco.
End table with natural oak top and structure in matt lacquered white metal.

ARONA

design by **Andrea Lucatello**

TAVOLINO ARONA ART. T6212

Tavolino realizzato con un piano in legno per sostenere due ali di vetro curvo ed avere oltre ad un normale piano d'appoggio anche un pratico portariviste.

Coffee table manufactured with a wooden base supporting two wings of curved glass, which adds a magazine rack to the product.

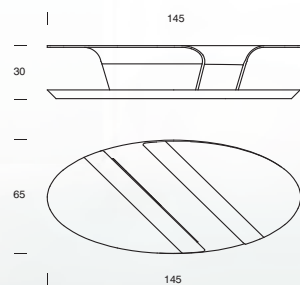

art. 6212

FINITURE VETRI GLASS FINISHING



V81
TRASPARENTE
TRANSPARENT



V100
EXTRA CHIARO TRASPARENTE
EXTRA CLEAR TRANSPARENT

FINITURE BASE LEGNO WOOD BASE FINISHING



14
NOCE CANALETTO
CANALETTO WALNUT



16
ROVERE SCURO TERMOTRATTATO
DARK OAK HEAT-TREATED



Arona_Art. 6212 14 V81
Tavolino con base in noce canaletto e piani in vetro curvo trasparente.
Coffee table with canaletto walnut base and transparent curved glass surfaces.

OSOWA

design by Studio 28

TAVOLINO OSOWA ART. T6984/6985

*Tavolino con struttura laccata bianca, noce canaletto o rovere scuro, con top e ripiano in vetro temperato.
Sia nella versione rettangolare sia nella versione quadrata Osowa da la possibilità di utilizzare la sua parte interna come aggiuntivo contenitore.
Pratico e di design rappresenta uno dei prodotti storici della collezione Tonin Casa.*

*Coffee table with lacquered white, Canaletto walnut or dark oak structure with top in tempered glass.
Available both square or rectangular, Osowa enable the use of its internal part as an extra storage unit.
A practical design product, a Tonin Casa classic.*

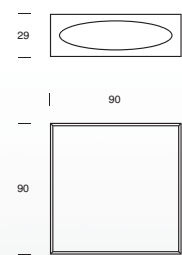

art. 6985

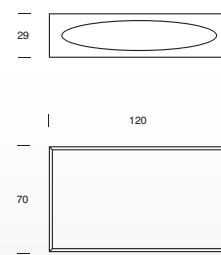

art. 6984

FINITURA STRUTTURA STRUCTURE FINISHING



01
BIANCO OPACO
MATT WHITE



14
NOCE CANALETTO
CANALETTO WALNUT



16
ROVERE SCURO
TERMOTRATTATO
DARK OAK
HEAT-TREATED

FINITURE TOP VETRO GLASS TOP FINISHING



V602
ACIDATO NERO
ETCHED BLACK



V636
EXTRA CHIARO ACIDATO
BEIGE
EXTRA CLEAR ETCHED BEIGE



V601
EXTRA CHIARO
ACIDATO BIANCO
EXTRA CLEAR ETCHED
WHITE



Osowa Art. 6984 14 V636
Tavolino rettangolare in noce canaletto e top in vetro extrachiaro temperato acidato beige.
Rectangular coffee table in canaletto walnut and top in etched extraclear tempered beige glass.

MISSOURI

design by **Studio 28**

TAVOLINO MISSOURI ART. T7317

*Tavolino con base in metallo cromato e piani in vetro temperato.
Doppio appoggio per la massima comodità ma sempre senza rinunciare al design.*

*Coffee table with base in chromed metal and tempered glass top.
Double different level surfaces for maximum leisure without giving up on design.*

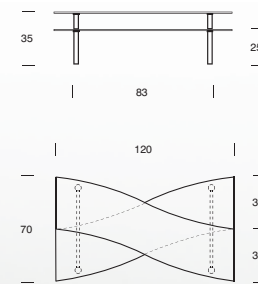

art. 7317

FINITURE VETRO
GLASS FINISHING



V2
NERO
BLACK



V101
EXTRA CHIARO BIANCO
EXTRA CLEAR WHITE



V160
EXTRA CHIARO CHAMPAGNE
EXTRA CLEAR CHAMPAGNE



Missouri_Art. 7317 V101

Tavolino con base in metallo cromato e piani sagomati in vetro extra chiaro temperato bianco.

Coffee table with base in chromed metal and top in white extra clear tempered profiled glass.

CENTRAL

design by **Studio 28**

TAVOLINI CENTRAL ART. T6281/6282/6284

Famiglia di tavolini di diverse dimensioni con struttura in metallo cromato e piano in vetro o in noce canaletto o rovere scuro. Central grazie alle svariate finiture e dimensioni si adatta a tutte le esigenze domestiche sempre all'insegna dello stile.

Group of coffee tables in different dimensions with a chromed metal structure and top available in tempered glass, Canaletto walnut or dark oak. Due to the many finishing and dimensions, Central can be easily adapted with style to all household needs.



Central Art. 6284 74 14
Tavolino rettangolare con
struttura in metallo cromato
nero e piano in legno noce
canaletto.

*Rectangular coffee table with
structure in black chromed
metal and top in canaletto
walnut.*

CENTRAL

design by Studio 28



Piani in vetro o legno da accostare a strutture in cromo o in cromo nero.

Glass or wooden tops to be matched with chromed or black chrome structures.

Central_Art. 6281 72 V2
Tavolino quadrato con struttura in metallo cromato e piano in vetro temperato nero.
Glass or wooden tops to be matched with chromed or black chrome structures.

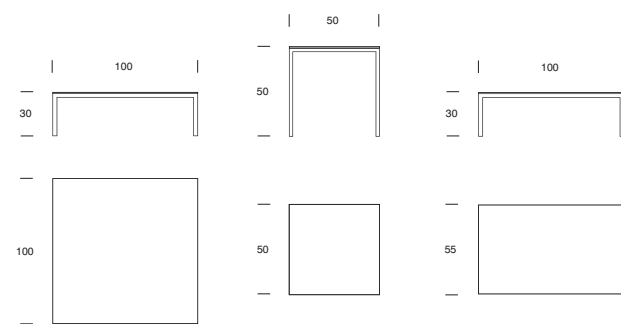

art. 6281

art. 6282

art. 6284

STRUTTURA STRUCTURE



74
CROMO NERO
BLACK CHROME



72
METALLO CROMATO
CHROMED METAL

FINITURA PIANO VETRO FINISHING GLASS TOP



V2
NERO
BLACK



V101
EXTRA CHIARO BIANCO
EXTRA CLEAR WHITE

FINITURA PIANO LEGNO FINISHING WOOD TOP



14
NOCE CANALETTO
CANALETTO WALNUT



16
ROVERE SCURO TERMOTRATTATO
DARK OAK HEAT-TREATED



Central_Art. 6281 74 16
Tavolino rettangolare con struttura in metallo cromato nero e piano in legno rovere scuro termotrattato.

Rectangular coffee table with structure in black chromed metal and top in thermo treated dark oak.

PARIOLI

design by Studio 28

TAVOLINI PARIOLI ART. T7315/T6274/T7315P

*Tavolino o servetto con base in metallo cromato e piano ellittico in marmo bianco carrara, nero marquinia o grigio.
Il prestigio del marmo si unisce al metallo cromato per proporre un tavolino decisamente di classe.*

*Coffee table or end table with metal chromed base and elliptical top in white Carrara, black Marquinia or grey marble.
The prestige of marble meets chromed metal to offer you a very classy occasional product.*



Parioli_Art. 7315 72 M101
Tavolino con struttura in metallo cromato e piano ellittico in marmo bianco di Carrara lucido.
Coffee table with chromed metal structure and top in elliptical glossy Carrara white marble.

PARIOLI

design by Studio 28

La vena preziosa del marmo rappresenta l'ingrediente fondamentale di questa collezione di tavolini.

The precious vein of marble is the fundamental ingredient in this collection of coffee tables.

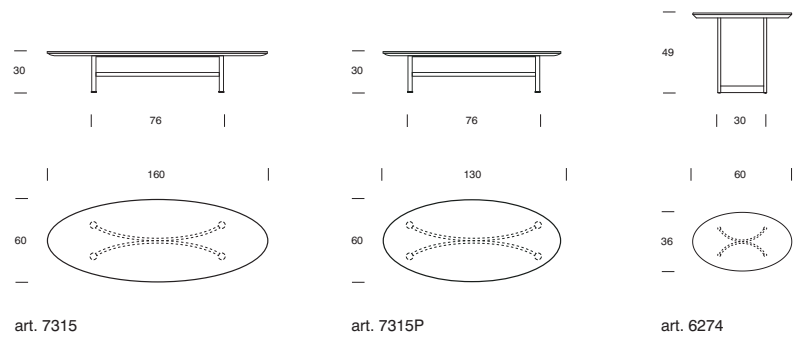

FINITURE PIANI
IN MARMO
MARBLE TOP
FINISHING



M101
BIANCO CARRARA LUCIDO
GLOSSY WHITE CARRARA



M102
NERO MARQUINA LUCIDO
GLOSSY BLACK MARQUINA

BASE



M72
METALLO CROMATO
CHROMED METAL

art. 7315

art. 7315P

art. 6274



Paroli Art. 6274 M102
Servetto con struttura in metallo cromato e piano ellittico in marmo nero marquina lucido.

End table with chromed metal structure and elliptical top in glossy black Marquina marble.

TUDOR

design by Studio 28

TAVOLINO TUDOR ART. T6630

*Tavolino con base in agglomerato di marmo e piano in vetro.
Un'eleganza moderna per una casa da vivere nell'armonia del vero design.*

*Coffee table with marble conglomerate base and tempered glass top.
A modern elegance for a home to be lived with the harmony of real design.*

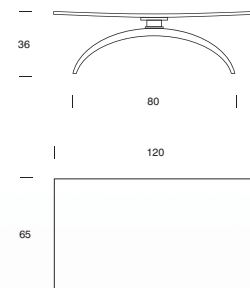

art. 6630_CSV

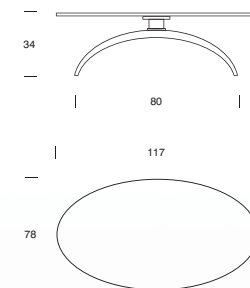

art. 6230_EFCV

FINITURE BASE BASE FINISHING



501
BIANCO LUCIDO
GLOSSY WHITE



502
NERO LUCIDO
GLOSSY BLACK



551
FANGO LUCIDO
GLOSSY MUD

FINITURA PIANO VETRO GLASS TOPS FINISHING



EFCV81
ELLITTICO TRASPARENTE
ELLIPTICAL TRANSPARENT



EFCV100
ELLITTICO EXTRA CHIARO
TRASPARENTE
ELLIPTICAL EXTRA CLEAR
TRANSPARENT

FINITURA PIANO VETRO CURVO FINISHING FLOOR CURVED GLASS



CSV81
TRASPARENTE
TRANSPARENT



CSV100
EXTRA CHIARO TRASPARENTE
EXTRA CLEAR TRANSPARENT



Tudor_Art. 6630 551 EFCV81
Tavolino con base in agglomerato di marmo fango lucido e piano in vetro trasparente.
Coffee table with base in glossy mud marble agglomerate and top in transparent glass.

AMBURGO

design by Studio 28

TAVOLINI AMBURGO ART. T6285/6286/6287

Tavolini rotondi con base realizzata con fili di metallo cromato e piano in vetro temperato. Disponibile in diverse finiture. Amburgo permette di creare delle belle composizioni da accostare per dare movimento al salotto.

Series of round occasional tables with a base made out chromed metal wires and tempered glass top. Available in different finishing. Amburgo enables to create some beautiful compositions to give the living area more motion.



Amburgo_Art. 6286 74 V136
Tavolino con base in metallo cromato nero e top in vetro temperato extra chiaro beige.

Coffee table with base in black chromed metal and top in tempered extraclear beige glass.

Amburgo_Art. 6285 74 V136
Tavolino con base in metallo cromato nero e top in vetro temperato extra chiaro beige.

Side table with base in black chromed metal and top in tempered extraclear beige glass.

AMBURGO

design by Studio 28

*Forme essenziali ed
estetica pulita ma
incisiva. Lo stile va
verso la leggerezza
e le cose semplici.*

*Essential shape and
clean but incisive
harmony.
Style moves to
lightness and
simple concepts.*



Amburgo_Art. 6285 72 V101
Tavolino con base in metallo cromato e top in
vetro temperato extra chiaro bianco.
*End table with chromed metal base and white
extra clear tempered glass top.*

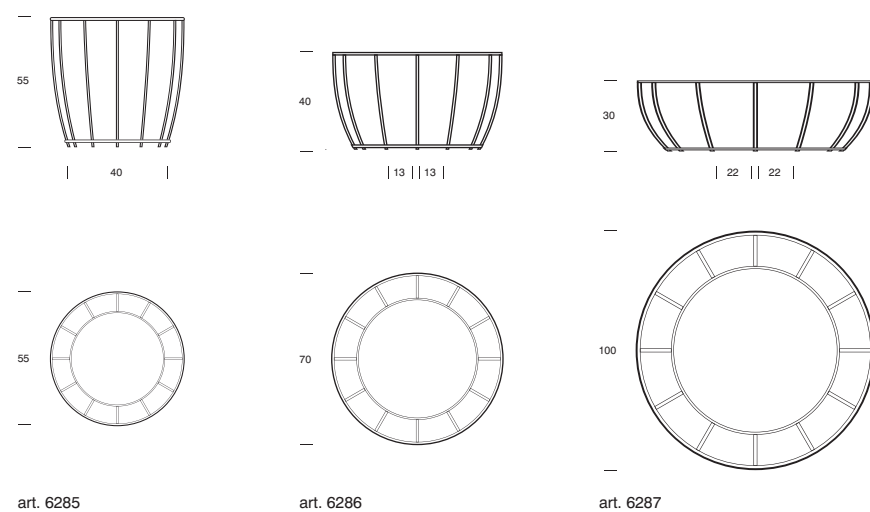

art. 6285

art. 6286

art. 6287

FINITURE BASE
BASE FINISHING



72
METALLO CROMATO
METAL CHROME



74
CROMO NERO
BLACK CHROME

FINITURE PIANO
VETRO
GLASS TOP FINISHING



V2
NERO
BLACK



V101
EXTRACHIAIRO BIANCO
EXTRA CLEAR WHITE



V136
EXTRACHIAIRO BEIGE
EXTRA CLEAR BEIGE



Amburgo_Art. 6287 72 V101
Tavolino con base in metallo cromato e
top in vetro temperato extra chiaro bianco.
*Coffee table with chromed metal base and
white extra clear tempered glass top.*

Amburgo_Art. 6285 72 V101
Tavolino con base in metallo cromato e
top in vetro temperato extra chiaro bianco.
*End table with chromed metal base and
white extra clear tempered glass top.*

AMANDA

design by Studio 28

TAVOLINO AMANDA ART. T6275

*Dall'unione del legno e del vetro nasce Amanda.
Il prestigio dei materiali e le linee morbide del design rappresentano un connubio di vera eleganza.*

*Coffee table with lacquered or wood veneered base and tempered profiled glass top.
The touch of the wood coupled with glass' transparency make this product original and unique.*

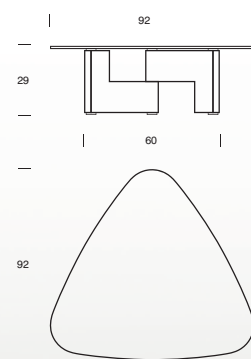

art. 6275

FINITURA STRUTTURA STRUCTURE FINISHING



01
LACCATO BIANCO OPACO
MATT WHITE LACQUERED



14
NOCE CANALETTO
CANALETTO WALNUT



16
ROVERE SCURO
TERMOTRATTATO
DARK OAK HEAT-TREATED

FINITURA PIANO TOP FINISHING



V81
TRASPARENTE
TRANSPARENT



V100
EXTRA CHIARO TRASPARENTE
EXTRA CLEAR TRANSPARENT



Amanda_Art. 6275 14 V81
Tavolino con base in legno
noce canaletto e top in vetro
sagomato trasparente.
*Coffee table with canaletto
walnut lacquered wooden
base and top in transparent
profiled glass.*

AMARANTO

design by Studio 28

TAVOLINO AMARANTO ART. T6811

*Tavolino rettangolare in vetro curvo con ripiano in legno o vetro.
La sinuosità del vetro ed il caldo tocco del legno rendono questo articolo semplice ma d'impatto.*

*Rectangular coffee table in curved glass with shelf in wood or glass.
The sinuosity of glass and the warm feel of wood make this article simple but effective.*

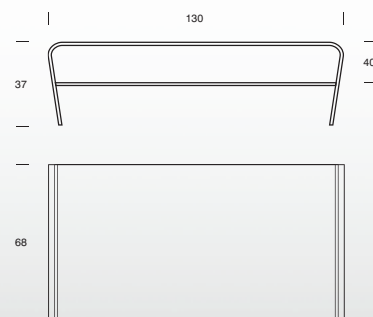

art. 6811

FINITURE STRUTTURA
VETRO
FINISHING GLASS
STRUCTURE



V81
TRAPIANTE
TRANSPARENT



V85
FUMÈ TRAPIANTE
TRANSPARENT FUMÈ



V100
EXTRA CHIARO TRAPIANTE
EXTRA CLEAR TRANSPARENT

FINITURE RIPIANO
LEGNO
FINISHING WOOD
SHELF



14
NOCE CANALETTO
CANALETTO WALNUT



16
ROVERE SCURO
TERMOTRATTATO
DARK OAK HEAT-TREATED

FINITURE RIPIANO
VETRO
FINISHING GLASS
SHELF



V2
NERO
BLACK



V101
EXTRA CHIARO BIANCO
EXTRA CLEAR WHITE

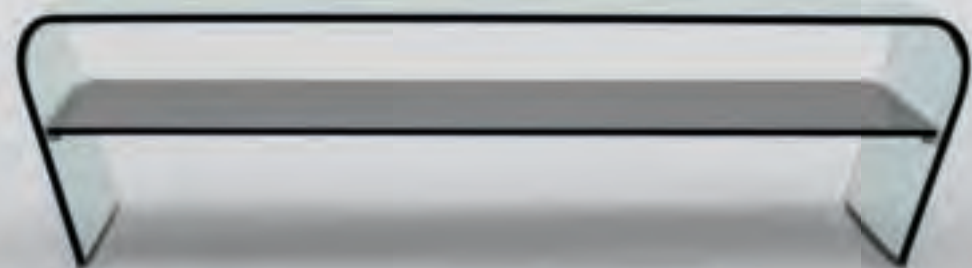

Amaranto_Art. 6811 V81 14
Tavolino in vetro curvo
trapiante con ripiano in
noce canaletto.
Coffee table in curved
transparent glass with shelf
in canaletto walnut.

ANEMONE

design by **Studio Tonin Creatives**

TAVOLINI ANEMONE ART. T6850/6846/6829

*Tavolini in vetro curvo disponibili in diverse finiture.
Forme semplici ed organiche caratterizzano Anemone.*

*Rectangular coffee table in curved glass available in different finishing.
Simple organic shapes are the main feature of Anemone.*



Anemone_Art.6829 V84 14
Tavolino/comodino in vetro
curvo bronzato trasparente
e ripiano in legno noce
canaletto.
Side table/nightstand in
curved bronze glass with
shelf in canaletto walnut.



Anemone_Art. 6850 V84
Tavolino in vetro curvo bronzato
trasparente.
*Coffee table in curved bronzed
transparent glass.*



Anemone_Art. 6846 V84
Tris di tavolini in vetro curvo
bronzato trasparente.
*Set of three side tables in
curved bronze glass.*

ANEMONE





design by Studio Tonin Creatives

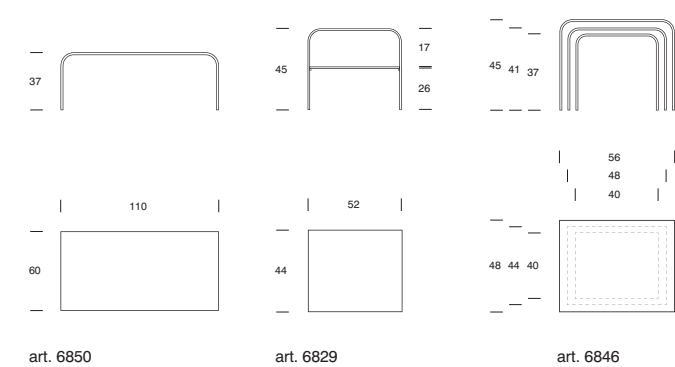





Anemone_Art. 6850 V2
Tavolino in vetro curvo
verniciato nero.
Coffee table in curved black
glass.



FINITURE STRUTTURA
VETRO
GLASS FINISHING
STRUCTURE

- | | | |
|---|--|---|
| 
V2
NERO
DISPONIBILE SOLO PER
TAVOLINO 6850
BLACK
ONLY FOR TABLE 6850 | 
V81
TRASPARENTE
TRANSPARENT | 
V84
BRONZATO
TRASPARENTE
TRANSPARENT
BRONZE |
| 
V85
FUMÉ TRASPARENTE
TRANSPARENT FUMÉ | 
V100
EXTRA CHIARO TRASPARENTE
EXTRA CLEAR TRANSPARENT | |

FINITURE RIPIANO
VETRO PER TAVOLINO
art.6229
FINISHING GLASS
SHELF FOR LOW
TABLES art.6229

- | | | |
|--|--|--|
| 
V2
NERO
BLACK | 
V81
TRASPARENTE
TRANSPARENT GLASS | 
V84
BRONZATO
TRASPARENTE
TRANSPARENT
BRONZE |
| 
V85
FUMÉ TRASPARENTE
TRANSPARENT FUMÉ | 
V100
EXTRA CHIARO TRASPARENTE
EXTRA CLEAR TRANSPARENT | |

FINITURE RIPIANO
LEGNO PER TAVOLINO
art.6829
FINISHING WOOD
SHELF FOR LOW
TABLES art.6829

- | | |
|---|---|
| 
14
NOCE CANALETTO
CANALETTO WALNUT | 
16
ROVERE SCURO
TERMOTRATTATO
DARK OAK HEAT-TREATED |
|---|---|

ALARIC

design by **Andrea Lucatello**

TAVOLINO ALARIC ART. T6223

Tavolino interamente realizzato in vetro curvo con doppio ripiano e portariviste.

Coffee table entirely in glass, with a double top surface and magazine rack.

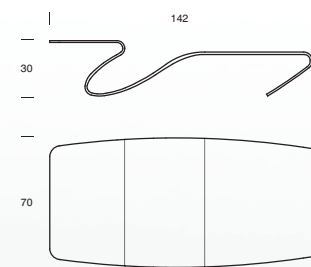

art. 6223

FINITURE
FINISHING



Alaric_Art. 6223 V81
Tavolino in vetro curvato
trasparente.
Coffee table in curved
transparent glass.

ALISSA

design by Studio Tonin Creatives

TAVOLINO ALISSA ART. T6806

Tavolino realizzato in vetro curvo dalle forme morbide prodotto con tecniche artigianali di curvatura del vetro.

Coffee table in curved glass with soft shapes, manufactured with artisan techniques of glass curving.

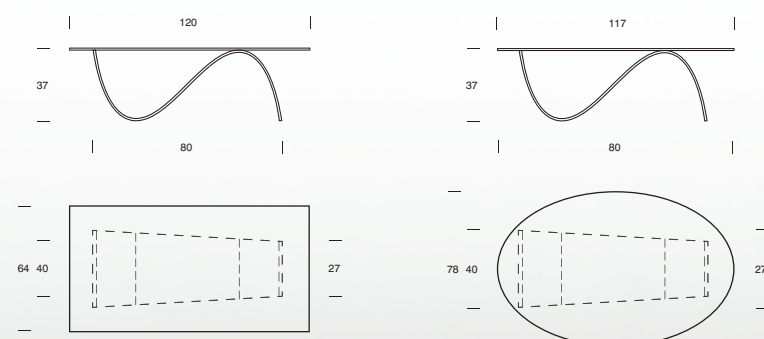

art. 6806 RM

art. 6806 E

FINITURA
FINISHING



Alissa_Art. 6806 V84 E
Tavolino in vetro curvo
bronzato trasparente.
Coffee table in curved
bronze transparent
glass.

NAVILE

design by Studio 28

TAVOLINO NAVILE ART. T6912

*Tavolino con basamento in agglomerato di marmo e piano in vetro curvato.
Semplice ma originale; un prodotto della collezione Tonin Casa senza tempo.*

*Coffee table with base in marble conglomerate and tempered glass top.
Simple yet original; a timeless Tonin Casa product.*

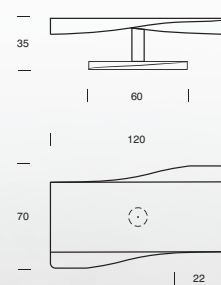

art. 6912

FINITURE BASE BASE FINISHING



501
BIANCO LUCIDO
GLOSSY WHITE



502
NERO LUCIDO
GLOSSY BLACK

FINITURE TOP VETRO GLASS TOP FINISHING



V2
VETRO NERO
BLACK



V81
VETRO TRASPARENTE
TRANSPARENT



V101
VETRO EXTRA CHIARO
BIANCO
EXTRA WHITE WHITE



V100
VETRO EXTRA CHIARO
TRASPARENTE
EXTRA WHITE
TRANSPARENT

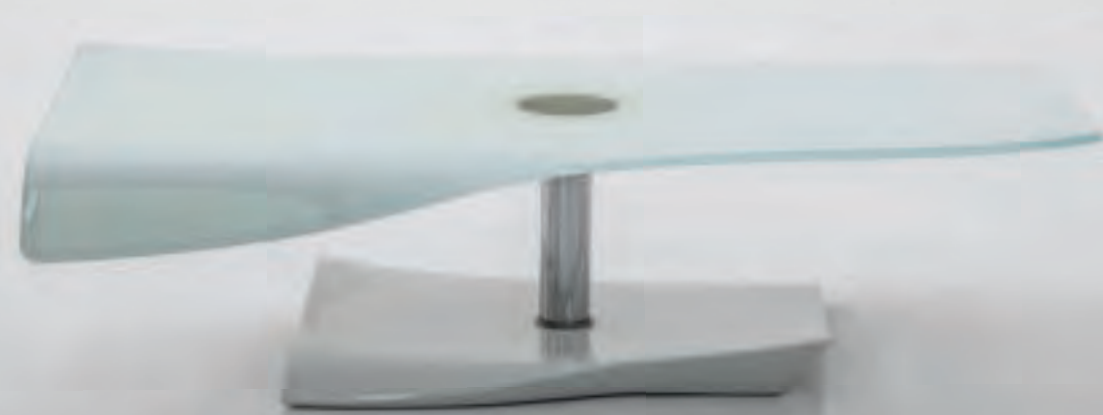

Navile_Art. 6912 502 V81
Tavolino con base in
agglomerato laccato nero
lucido e top in vetro curvo
trasparente.

*Coffee table with base in
lacquered glossy black
marble agglomerate and top
in transparent curved glass.*

ARIEL

design by **Studio Tonin Creatives**

TAVOLINI ARIEL ART. T6814/6832

*Tavolino realizzato tramite speciali tecniche di lavorazione del vetro.
Il basamento è una vera e propria scultura di vetro che genera mille riflessi e rende singolare Ariel.
Disponibile in due diverse dimensioni.*

*Coffee table made by using special glass manufacturing techniques.
The base is a proper glass sculpture that creates hundreds of peculiar reflexions.
Available in two different dimensions .*

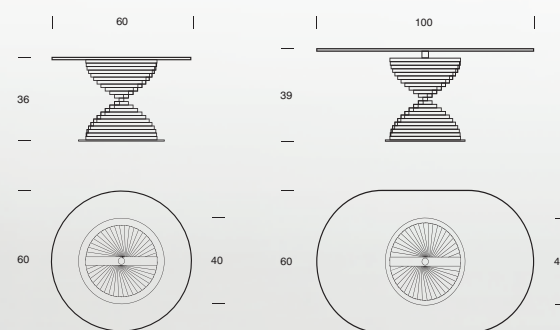

art. 6814

art. 6832

FINITURE
FINISHING



V81
TRASPARENTE
TRANSPARENT



V100
EXTRA CHIARO
TRASPARENTE
EXTRA CLEAR
TRANSPARENT



V85
FUME TRASPARENTE
TRANSPARENT FUME



Ariel Art. 6814 V81
Tavolino in vetro trasparente.
Side table in transparent glass.

PAVONES

design by **Nicola Tonin**

TAVOLINO PAVONES ART. T8105

Tavolino con struttura in metallo cromato e piano in vetro curvo.

La curvatura del vetro permette di avere un doppio appoggio che rende Pavones estremamente funzionale ed unico nel suo genere.

Coffee table with chromed metal structure and tempered glass top.

The curve of the glass enables to have two different level surfaces which makes Pavones extremely functional and unique in its own range.

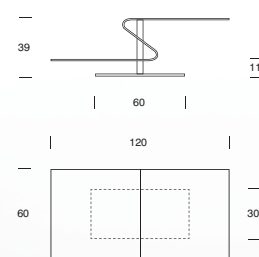

art. 8105

FINITURE
FINISHING



V2
NERO
BLACK



V81
TRASPARENTE
TRANSPARENT



V100
EXTRA CHIARO TRASPARENTE
EXTRA CLEAR TRANSPARENT



V101
EXTRA CHIARO BIANCO
EXTRA CLEAR WHITE



Pavones_Art. 8105 V101
Tavolino in vetro curvo
extrachiaro bianco.
Coffee table in curved
extraclear white glass.

ANDORRA

design by **Nicola Tonin**

TAVOLINO ANDORRA ART. T6293

*Tavolino con base in metallo laccato o cromato e piano in vetro temperato o legno.
Adachi è un pratico servetto da avvicinare al divano o da utilizzare come comodino per un letto.*

*End table with base in chromed or lacquered metal and tempered glass top.
Andorra is a practical end table to place next to the sofa or can be used as a bedside.*



Andorra_Art.6293 72 V2
Tavolino con base in metallo cromato e top in vetro nero.
Side table with base in chromed metal and top in black glass.

ANDORRA

design by Nicola Tonin

*Adatto a tutte le occasioni,
disponibile nelle finiture più
svariate, pratico e di design,
Andorra incontra tutti i gusti.*

*Ideal for any occasion,
available in different finish,
practical and stylish, Andorra
meets anyone's taste.*

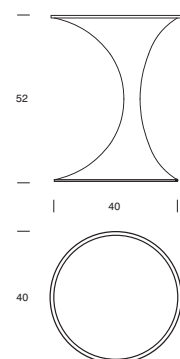

art. 6293

BASE
BASE



01
BIANCO OPACO
MATT WHITE



02
NERO OPACO
MATT BLACK



60
CHAMPAGNE OPACO
MATT CHAMPAGNE



72
METALLO CROMATO
CHROMED METAL



40
BLU TURCHESE
TURQUOISE BLUE



09
ARANCIO SALMONE
SALMON

PIANO IN VETRO
GLASS TOP



V2
NERO
BLACK



V101
EXTRA CHIARO BIANCO
EXTRA CLEAR WHITE



V160
EXTRA CHIARO CHAMPAGNE
EXTRA CLEAR CHAMPAGNE

PIANO IN LEGNO
WOODEN TOP



14
NOCE CANALETTO
CANALETTO WALNUT



16
ROVERE SCURO
TERMOTRATTATO
DARK OAK HEATTREATED



17
ROVERE NATURALE
NATURAL OAK

Andorra Art.6293 40 14
Tavolino con base laccata
blu turchese e top in noce
canaletto.

*Side table with base
lacquered blue turquoise
and top in canaletto walnut.*

Andorra Art.6293 09 16
Tavolino con base laccata
arancio salmone e top in
rovere scuro.

*Side table with base
lacquered orange salmon
and top in dark oak.*

DETROIT





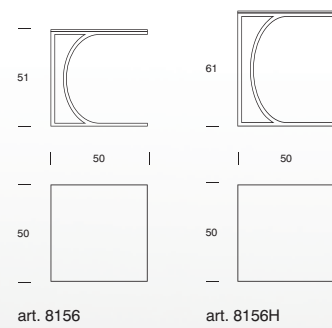

design by Studio 28

TAVOLINO DETROIT ART. T8156/8156H

Tavolino in metallo cromato, con piano in vetro temperato o noce canaletto, rovere scuro e rovere naturale, che funge da pratico servetto. Ideale per chi ha poco spazio ed ha bisogno di avere un piano di appoggio vicino al divano o letto.

Side or end table with a chromed metal structure and top available in tempered glass, Canaletto walnut, dark or light oak. Ideal for those who have little room and need a surface next to the bed or sofa.



FINITURA STRUTTURA STRUCTURE FINISHING	 72 CROMO CHROME	 74 CROMO NERO CHROME BLACK	
FINITURE TOP VETRO GLASS TOP FINISHING	 V2 NERO BLACK	 V101 EXTRA CHIARO BIANCO EXTRA CLEAR WHITE	 160 EXTRA CHIARO CHAMPAGNE SU RICHIESTA EXTRA CLEAR CHAMPAGNE ON REQUEST
FINITURE TOP LEGNO WOOD TOP FINISHING	 14 NOCE CANALETTO CANALETTO WALNUT	 16 ROVERE SCURO TERMOTRATTATO DARK OAK HEAT-TREATED	



Detroit_Art. 8156 74 14
Tavolino con struttura in metallo cromato nero e top in noce canaletto.
Side table with structure in black chromed metal and top in canaletto walnut.

AIRONE

design by Studio Tonin Creatives

TAVOLINO AIRONE ART. T6272

Tavolino girevole realizzato in MDF laccato o rivestito legno. Ideale sia come tavolino ma anche come piccola libreria o contenitore per oggetti. Linee geometriche e tanta funzionalità sono le caratteristiche salienti di Airone.

Revolving coffee table in lacquered MDF or wood veneered. Ideal both as a coffee table, but also as a small bookshelf or storage unit. Geometrical lines and plenty of functionality are the main features of Airone.

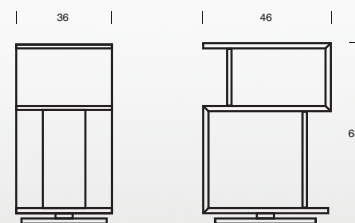

art. 6272

FINITURE STRUTTURA
STRUCTURE FINISHING



01
BIANCO OPACO
MATT WHITE



02
NERO OPACO
MATT BLACK



14
NOCE CANALETTO
CANALETTO WALNUT



16
ROVERE SCURO
TERMOTRATTATO
DARK OAK HEAT-TREATED



Airone_Art. 6272 01
Tavolino girevole con vani contenitivi laccato bianco opaco e finitura specchio. Swivelling side table in matt white lacquered wood and mirror finish supports.



ADACHI

design by Studio 28

TAVOLINO ADACHI ART. T8155/8155H

*Tavolino con base a goccia realizzata in agglomerato di marmo, stelo in metallo cromato e piano in vetro temperato.
Adachi è perfetto in coppia ed in diversa altezza, poiché riesce a dare un tocco di eleganza e dinamicità al salotto.*

*Coffee table with drop profiled base in marble conglomerate, stem in chromed metal and tempered glass top.
Adachi is perfect as a twin set in two different heights, as it gives a touch of elegance and dynamicity to the living room.*

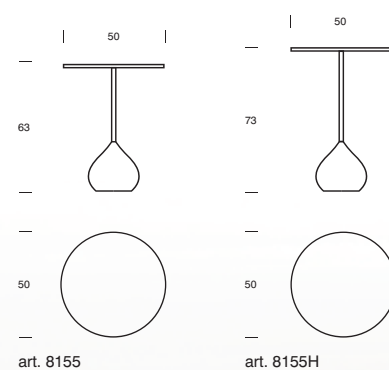

BASE
BASE



S01
BIANCO LUCIDO
GLOSSY WHITE



S02
NERO LUCIDO
GLOSSY BLACK



S60
CHAMPAGNE LUCIDO
GLOSSY CHAMPAGNE

PIANO VETRO
GLASS TOP



V81
TRASPARENTE
TRANSPARENT



V100
EXTRA CHIARO TRASPARENTE
EXTRA CLEAR TRANSPARENT



Adachi_Art.8155T 560 V81

Tavolino con base in agglomerato di marmo laccato champagne lucido e top in vetro trasparente.

Coffee table with base in laquered in glossy champagne marble agglomerated and top in transparent glass.

DIVA

design by **Studio Tonin Creatives**

TAVOLINO DIVA ART. T6295

*Pratico servetto salva spazio da accostare al divano o al letto.
Disponibile sia nella versione laccata che rivestita legno in diverse finiture.*

*Practical end table, a space saver to be place next to the sofa or the bed.
Available either in the lacquered version or wood veneered.*



Diva_Art. 6295 14
Tavolino in legno rivestito
noce canaletto.
Wooden end table
veneered in canaletto
walnut.

DIVA

design by **Studio Tonin Creatives**



Colora la casa con i nostri complementi funzionali e di design.

Brighten up your house with our stylish and functional occasional furniture.

Diva_Art.6295 09
Tavolino in legno laccato arancio salmone poro aperto.
Side table in salmon lacquered open pore wood.



Diva_Art.6295 24
Tavolino in legno laccato bianco poro aperto.
Side table in white lacquered open pore wood.

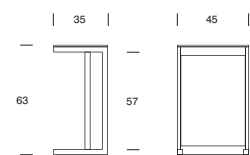

art. 6295

FINITURE

FINISHING



FLY

design by **Angelo Tomaiuolo**

PORTARIVISTE FLY ART. T7491

*Portariviste realizzato in metallo curvato e rivestito in ecopelle.
Un oggetto di uso quotidiano, studiato nel minimo dettaglio per non lasciare nulla al caso.*

*Eco-leather covered magazine rack made out of curved metal.
An everyday life object, designed into its minimum detail.*

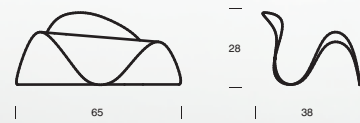

art. 7491

FINITURE
RIVESTIMENTO
COVERING FINISHING

PER IL CAMPIONARIO
COMPLETO VEDI LE
PAGINE FINALI
FOR COMPLETE
SAMPLES SEE THE FINAL
PAGES



S
ECOPELLE
ECO LEATHER

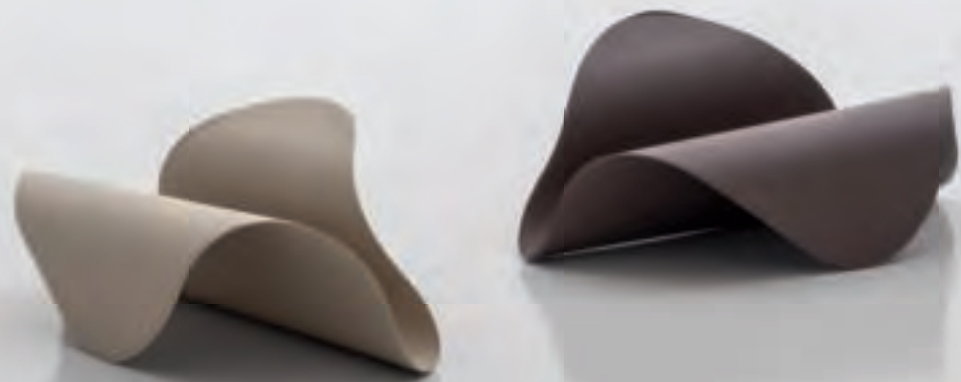

Fly_Art. 7491 S77
Portariviste rivestito in ecopelle
viola melanzana.
Magazine rack covered in
aubergine purple eco-leather.

complementi:
Specchiere

*occasional
furniture
mirrors*

*Skin
Granada
Costantia
Olmi
Toshima
Kolonaky*



SKIN

design by **Nicola Tonin**

SPECCHIERA SKIN ART. T7530

Specchio bronzato o argentato ideato per creare delle originali pareti che si arricchiscono di note artistiche.

Bronzed or silvered mirror, to gift the room with a rich artistic note.

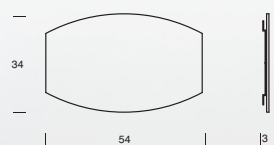

art. 7530

FINITURE
FINISHING



V45
SPECCHIO ARGENTATO
SILVER MIRROR



V184
SPECCHIO BRONZO
BRONZE MIRROR



Skin_Art. 7530 V184
Specchio finitura
bronzata.
Mirror with bronzed
finish.

GRANADA

design by **Angelo Tomaiuolo**

SPECCHIERA GRANADA ART. T5758/T5759

Specchiera bronzata con serigrafia ideale per creare delle composizioni eleganti ed originali da adattare in particolare al programma Granada.

Bronzed mirror with serigraphy ideal to create elegant and original compositions to be easily adapted to the Granada program.

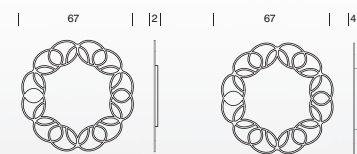

art. 5758

art. 5759

FINITURE
FINISHING



V194
SPECCHIO BRONZO
BRONZE MIRROR



V848
TRASPARENTE BRONZO
SERIGRAFATO
TRANSPARENT BRONZE
WITH SERIGRAPHY



Granada_Art. T5758 - T5759
Specchio bronzato e
serigrafato.
Bronzed mirror with serigraphy.

COSTANTIA

design by **Studio 28**

SPECCHIERA COSTANTIA ART. T7519 SR/SQ

*Specchiera bisellata disponibile sia nella versione rettangolare sia nella versione quadrata.
Atmosfere uniche, riflessioni moderne che animano la casa.*

*Bevelled mirror available both rectangular or square.
Unique atmospheres, modern reflections that animate your home.*

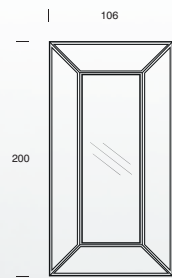

art. 7519 SR

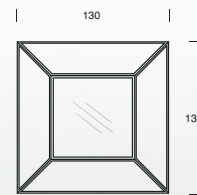

art. 7519 SQ

FINITURE
FINISHING



V45
SPECCHIO ARGENTO
SILVER MIRROR



Costantia_Art.7519 SR
Specchiera con bisello
rettangolare.
Rectangular bevelled
mirror.



OLMI

design by **Nicola Tonin**

SPECCHIERA OLMI ART. T7507

Specchiera ellittica con cornice verniciata.

Perfetto in una camera da letto come in un salotto per dare un tocco glamour senza tempo.

Elliptical mirror with painted frame.

Perfect in a bedroom, as well as in a living area, to add a touch of timeless glamour.

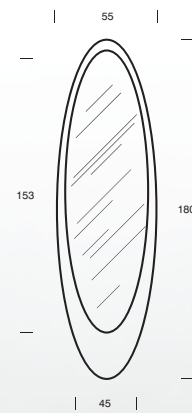

art. 7507

FINITURE
FINISHING



V2
SERIGRAFATO VERNICIATO
NERO
BLACK PAINTED



V84
SERIGRAFATO BRONZE
TRASPARENTE
PAINTED BRONZE TRANSPARENT



V101
SERIGRAFATO EXTRA CHIARO
VERNICIATO BIANCO
PAINTED EXTRA CLEAR WHITE



V160
SERIGRAFATO EXTRA CHIARO
VERNICIATO CHAMPAGNE
PAINTED EXTRA CLEAR CHAMPAGNE



Olmi_Art. 7507 V84
Specchio ellittico con cornice in
vetro bronzato trasparente.
Elliptical mirror with frame in
bronze transparent glass.



TOSHIMA

design by **Studio Tonin Creatives**

SPECCHIERA TOSHIMA ART. T5030/5032

*Specchiera con cornice verniciata. Semplice ma adattabile a tutte le situazioni
Toshima è disponibile sia nella versione rettangolare che quadrata.*

*Mirror with painted frame. Simple yet adaptable to all situations,
Toshima is available both in the rectangular version and square.*



art. 5030

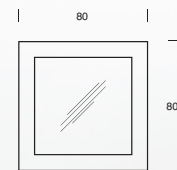

art. 5032

FINITURE FINISHING



V2
SERIGRAFATO VERNICIATO
NERO SPECCHIO ARGENTATO
PAINTED BLACK
(SILVER MIRROR)



V84
SERIGRAFATO TRASPARENTE
SPECCHIO BRONZO
PAINTED TRANSPARENT
(BRONZE MIRROR)



V101
SERIGRAFATO EXTRACHIARO
VERNICIATO BIANCO
SPECCHIO ARGENTATO
PAINTED EXTRA CLEAR WHITE
(SILVER MIRROR)



V136
SERIGRAFATO EXTRACHIARO
VERNICIATO BEIGE SPECCHIO
ARGENTATO
PAINTED EXTRA CLEAR BEIGE
(SILVER MIRROR)



Toshima_Art. 5032 V101
specchio quadrato con
cornice in vetro extra
chiaro verniciato bianco.
Square mirror with white
extra clear glass frame.

KOLONAKY

design by Studio 28

SPECCHIERA KOLONAKY ART. T7526

Specchiera ellittica rivestita. Kolonaky è pratica ed elegante; può essere trasportata facilmente per essere utilizzata in svariate occasioni.

*Elliptical mirror covered in leather or eco-leather.
Kolonaky is practical and elegant; is can be easily moved into another ambient to be used on different occasions.*

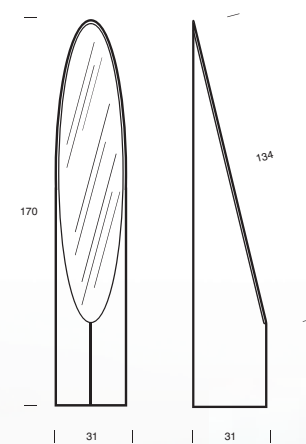

art. 7526

RIVESTIMENTO
COVERING
PER IL CAMPIONARIO
COMPLETO VEDI LE
PAGINE FINALI
FOR COMPLETE SAMPLES
SEE THE FINAL PAGES



Kolonaky_Art. 7526 S34/77
Specchiera rivestita in ecopelle
blu e viola melanzana.
Mirror covered in blue and
purple aubergine eco-leather.

Campionario | sample collection

FINITURE E COLORI FINISHING AND COLORS

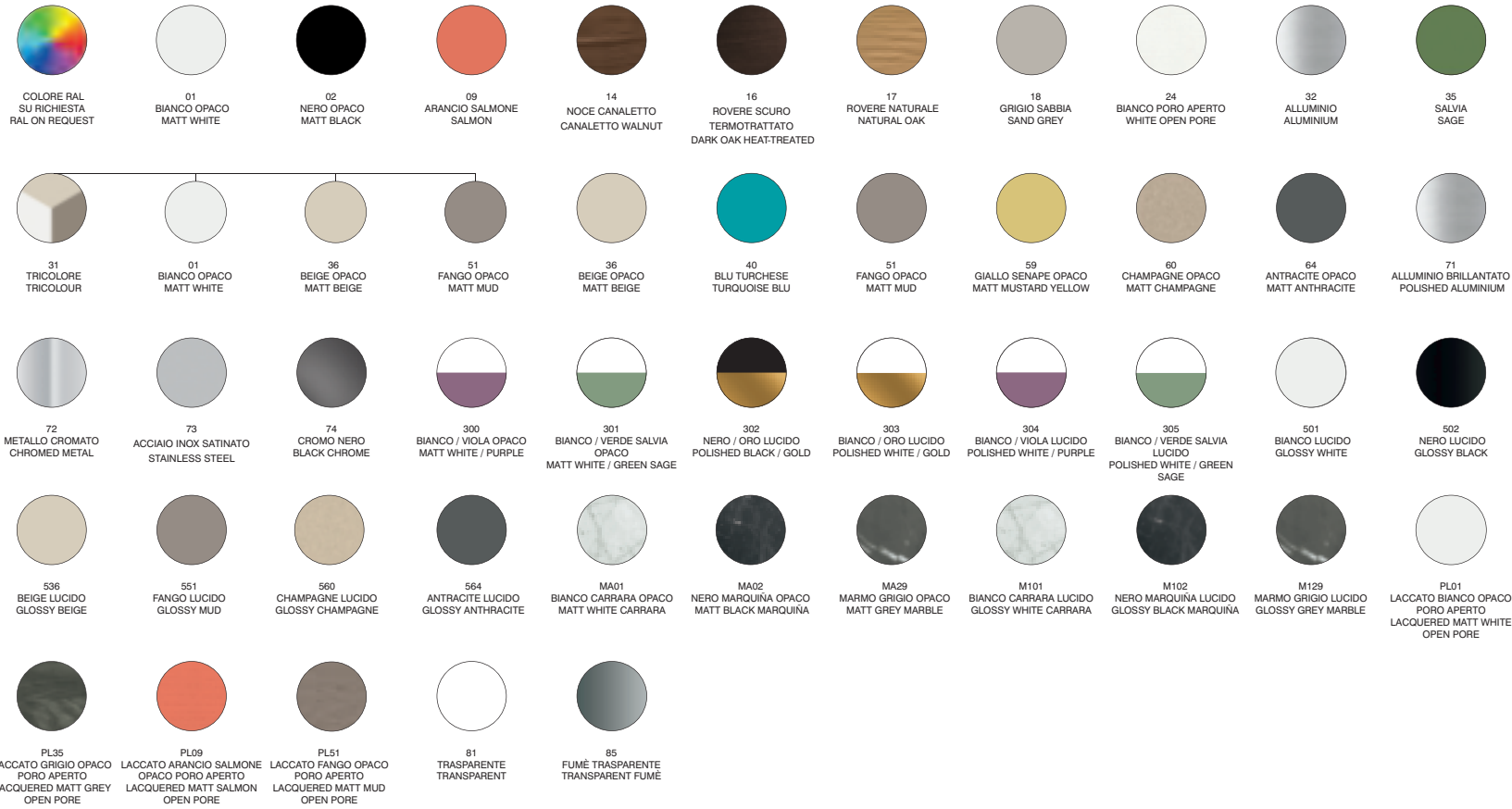

V - VETRI GLASSES

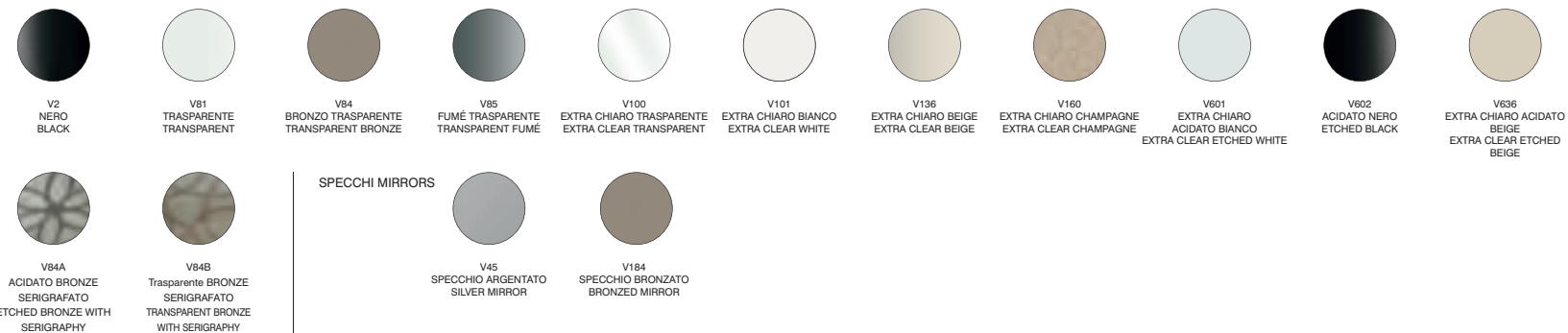

P - PELLE LEATHER



LE FINITURE E I COLORI SONO INDICATIVI E POSSONO SUBIRE VARIAZIONI DOVUTE ALLA TECNICA DI STAMPA TIPOGRAFICA. FINISHING AND COLOURS ARE APPROXIMATE AND THEY MAY VARY DURING THE LETTERPRESS PROCESS.

P - PELLE LEATHER



PF - PELLE FIORE LEGGERMENTE RITOCATO GRAIN LEATHER SLIGHTLY IMPROVED

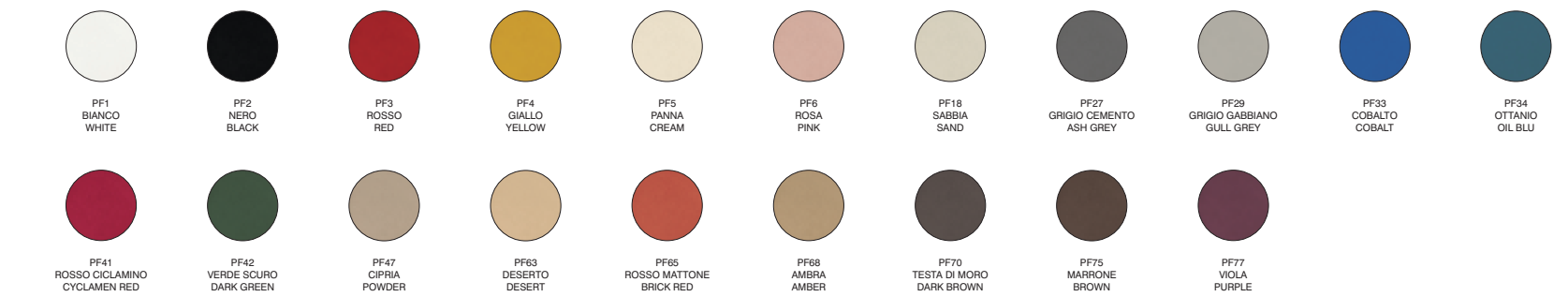

PN - PELLE NABUK



S - ECOPELLE ECO LEATHER



TV - TESSUTO VERBENA VERBENA FABRIC

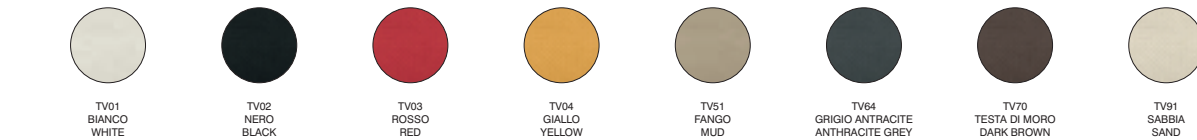

LE FINITURE E I COLORI SONO INDICATIVI E POSSONO SUBIRE VARIAZIONI DOVUTE ALLA TECNICA DI STAMPA TIPOGRAFICA. FINISHING AND COLOURS ARE APPROXIMATE AND THEY MAY VARY DURING THE LETTERPRESS PROCESS.

TN - TESSUTO NINFEA NINFEA FABRIC



K - CUIOIO LEATHER

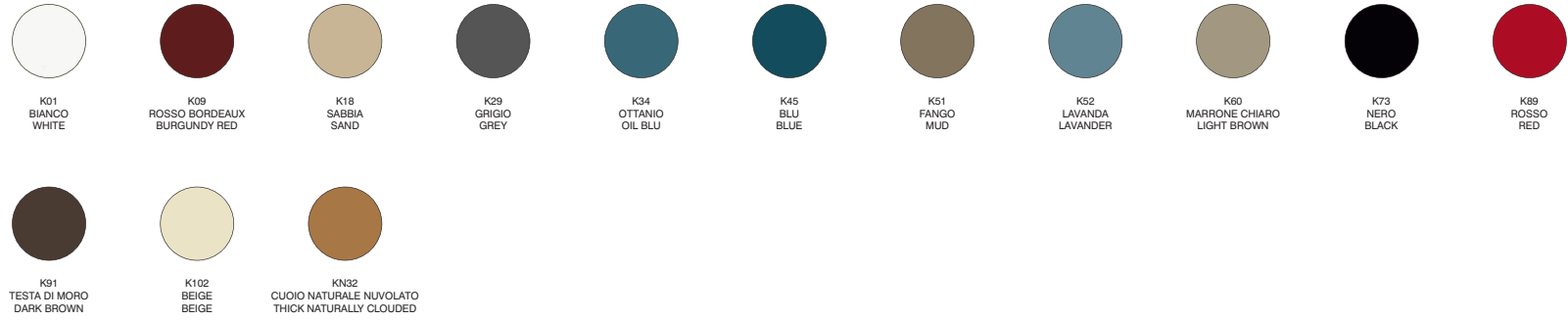

TECNORIL



MELAMINICO MELAMINE



LE FINITURE E I COLORI SONO INDICATIVI E POSSONO SUBIRE VARIAZIONI DOVUTE ALLA TECNICA DI STAMPA TIPOGRAFICA.
FINISHING AND COLOURS ARE APPROXIMATE AND THEY MAY VARY DURING THE LETTERPRESS PROCESS.

Direzione artistica: Moira Scalco
Nicola Tonin
Coordinamento fotografico: Raffaele Paolucci
Styling: Valentina Brunetta
Stefano Bortoletto
Photo: Federico Carretta
Grafica: Nave Pier Giorgio Eurekip
Studio Tonin Creatives
Stampa: Grafiche Antiga
Thanks to : Egizia
Cosi Tabellini
Ceramiche Maroso

Stampato in Italia Aprile 2014